

# **Basin Faucet Installation Manual**

**W-301(ES)**

# Warranty Duration

All components of this faucet system are covered under a lifetime limited warranty, ensuring they are free from defects in material and workmanship for the original purchaser.

# Repair and Replacement

If the product shows defects in material or workmanship under normal use and within the warranty period, we will, at our discretion, either repair the product or provide a replacement at no cost to the original purchaser. Please note that proof of purchase (e.g., an invoice) is required when requesting service. The warranty does not cover damages caused by improper installation, misuse, or modifications.

# Exclusions

We shall not be responsible for the following cases:

- Damage to the product caused by improper installation, misuse, unauthorized repair or replacement, or abuse (including damage during shipment).
- Damage to the product caused by improper dismantling after installation.
- Damage resulting from abnormal water pressure or impurities in water pipes, which is not covered under this warranty.
- Rust on the product due to insufficient care and maintenance, which is not covered under this warranty.
- Damage caused by natural disasters such as fire, flood, earthquake, lightning storms, etc., which is not covered under this warranty.

I hope this helps! If you have any further questions or concerns, please let me know.

# Having Trouble? Contact us.

✉ Email: [info@faucetsupport.com](mailto:info@faucetsupport.com)

☎ Toll Free: 1-888-969-6880



**M1224  
SFS-1152**

## **CONTENT**

**Basin Faucet Installation Manual ----- (1-6)**

## **CONTENIDO**

**Manual de Instalación del Grifo para Lavabo ----- (7-12)**

## ◆ Installation and Maintenance Instructions

1. Check the accessories list to verify that all parts are complete in this package.
2. Do not disassemble the main body by yourself.
3. Connect inlet pipes to supply valves.
4. Make sure inlet pipes and supply valves have no impurities and are cleaned, with no impurities in the pipeline.
5. After installation, check all joints for leakages.
6. Do not leave the faucet exposed to a severely corrosive environment.

### Do's

1. In order to keep the mixer surface bright, please clean the mixer regularly.
2. Rinse the faucet with clean water and wipe it with a soft cotton cloth.
3. Use one of the following cleaners to remove dirt from the surface:
  - a. Mild liquid cleaner.
  - b. Colorless glass cleaner and powder cleaner that do not cause abrasion and can be dissolved completely.
  - c. Polish liquid that does not cause abrasion.

### Don'ts

1. Avoid using cleaning powder, harsh cleaning chemicals, brushes and coarse cloth to prevent scratching and friction.
2. Do not use acid cleaners to clean the faucet as they may cause surface corrosion of the faucet. If the faucet is exposed to harmful acid substances, please rinse it immediately with water.

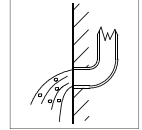

### Tools Needed:

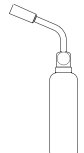
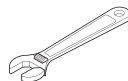
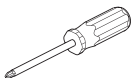

◆ **Hot and Cold Basin Faucet Set**  
**Accessories List**

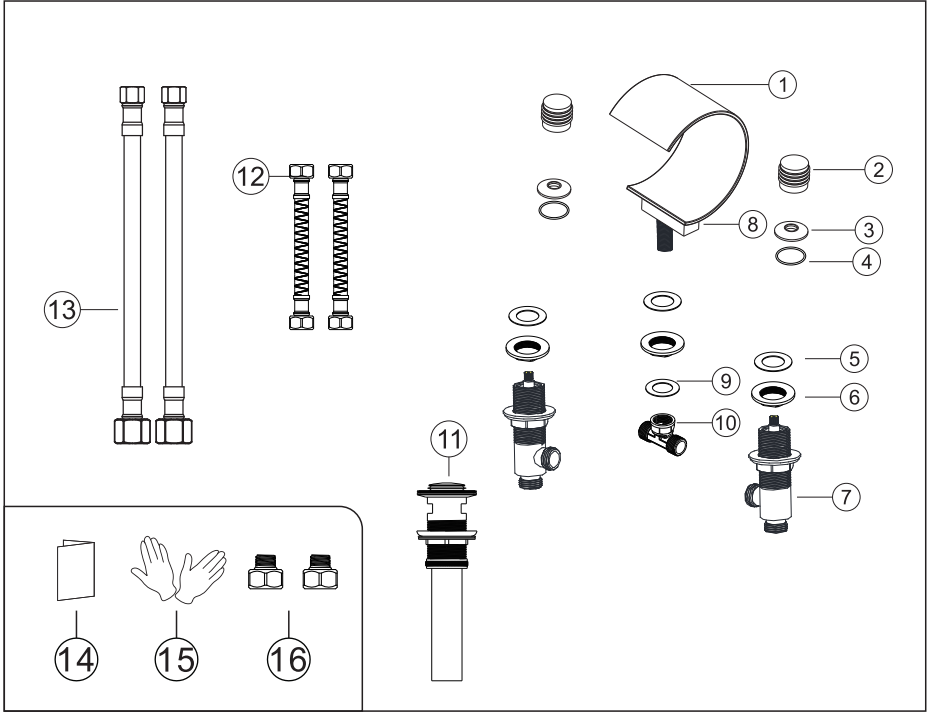

No.	Part name	Qty	No.	Part name	Qty
1	Faucet body	1	9	Tee gasket	1
2	Handle	2	10	Tee	1
3	Handle flange	2	11	Drain assembly	1
4	O-shaped abrasion-resistant ring	2	12	Connector hoses	1 pair
5	Gasket	3	13	Hot and cold hoses	1 pair
6	Fixing nut	3	14	Instruction manual	1
7	Control water body	2	15	Gloves	1 pair
8	Faucet Base	1	16	Hose adapter change G9/16 to G1/2	2

## ◆ Basin Faucet Installation

### Step 1

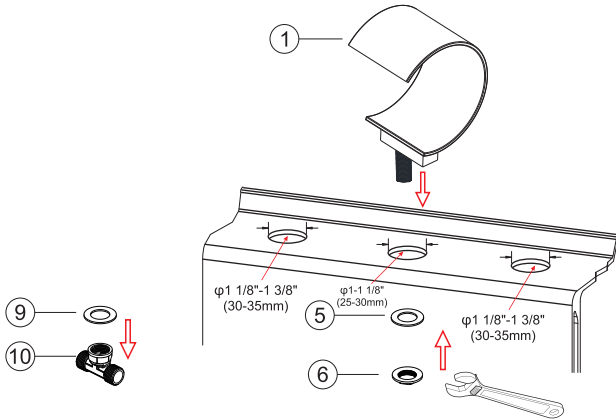

Pass the brass part through the basin's faucet hole. Fit the faucet body gasket ⑤ and mounting nut ⑥ in sequence onto the brass part from underneath the basin. Tighten the mounting nut securely using a wrench. Avoid overtightening to prevent damaging the basin or components. Place the tee gasket ⑧ into the tee ⑨, then attach the tee to the brass component. Ensure all parts are properly aligned and securely connected.

### Step 2

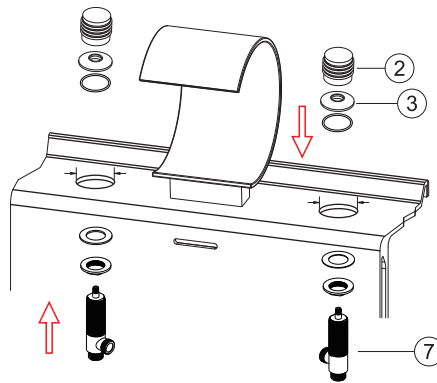

Remove the handle flange ③ and place it over the basin's faucet holes. From underneath the basin, connect the control water body ⑦ to the handle flange by aligning them with the basin holes. Secure the connection by tightening the fittings. Ensure all components are correctly aligned to avoid leaks. Attach the handles to the control water body and tighten them securely using the provided tools or screws. Avoid overtightening to prevent damage. Do not disassemble the valve yourself, as improper handling may cause leakage or compromise functionality.

## ◆ Basin Faucet Installation

### Step 3

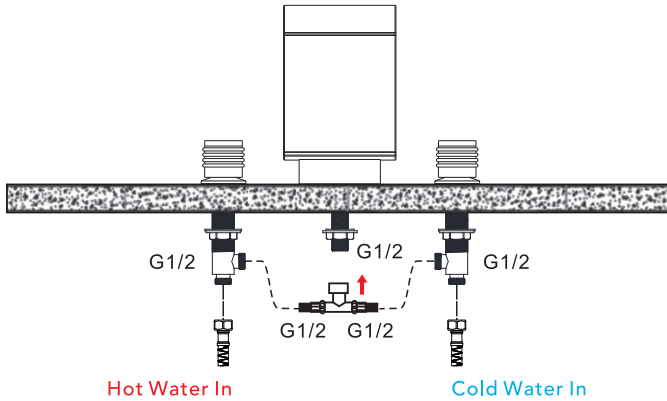

Attach one end of the inlet hoses to the control water bodies and the other end to the tee. Ensure all connections are aligned properly, then securely tighten them using a wrench or hand-tighten as needed. Use the red hose for the hot water supply and the blue hose for the cold water supply. Double-check that each hose is connected to the corresponding water source to avoid misconfiguration.

### Step 4

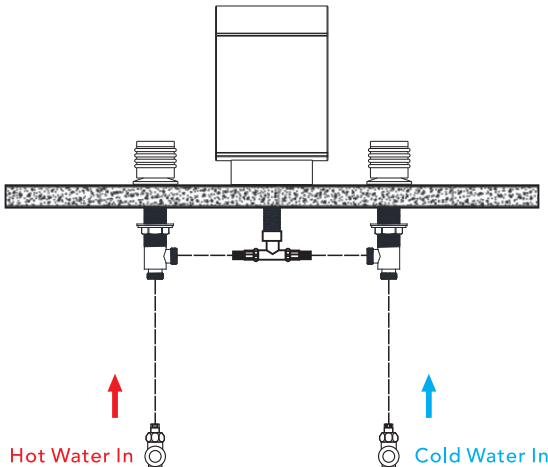

Connect one end of each hose to the angle valves and the other end to the Valve Body. Attach the left hose to the hot water supply (angle valve) and the right hose to the cold water supply (angle valve). Ensure all connections are properly tightened to prevent leaks.

## ◆ Drain Assembly Installation

### Step1

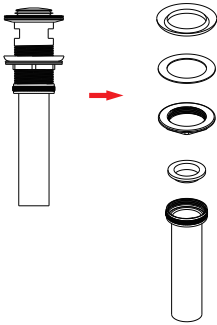

- Begin disassembling the drain assembly by removing the bottom section first. As illustrated in the image on the left, carefully detach all components step by step.

### Step2

- Insert the upper section of the drain assembly into the basin's drain hole. From underneath the basin, sequentially install the rubber gasket, washer, and fixing brass sleeve onto the threaded tailpiece. Carefully rotate the brass sleeve clockwise until secure, but avoid overtightening to prevent damage to the basin or drain components.
- Finally, rotate and tighten the lower section of the drain assembly downward to secure all components and complete the installation.

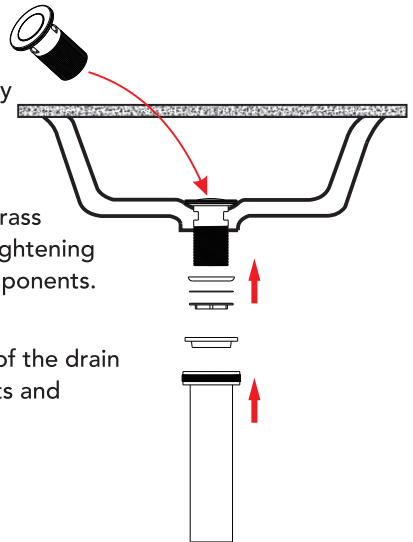

## ◆ Drain Assembly Installation

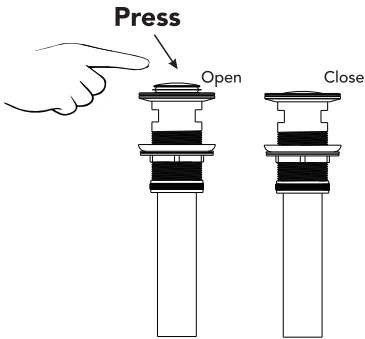

Press the pop-up button located at the top of the drain assembly to open or close the drain outlet.

### ⚠ Notice:

1. **Sealing Test:** Turn on the faucet and allow water to run for several minutes. Carefully inspect the drain assembly and the drainage pipe connections for any signs of leaks. If leaks are detected, adjust the tightness of the gasket and nuts to ensure a proper seal.
2. **Drainage Speed Test:** Check that water flows smoothly through the drain without any blockages or signs of slow drainage. Address any issues promptly to avoid future performance problems.
3. **Selecting the Appropriate Drain:** Different basin designs may require specific sizes and types of drains. Ensure the drain selected is compatible with your basin's size, style, and specifications before installation.

## ◆ Instalación y Cuestiones de Mantenimiento

1. Compruebe la lista de accesorios para verificar que todas las piezas están completas en este paquete.
2. No desmonte el cuerpo principal por su cuenta.
3. Conecte las tuberías de entrada a las válvulas de suministro.
4. Asegúrese de que las tuberías de entrada y las válvulas de suministro no tengan impurezas y estén limpias, y de que no haya impurezas en la tubería.
5. Después de la instalación, compruebe que todas las uniones no presenten fugas.
6. No deje el grifo expuesto a un entorno altamente corrosivo.

### Qué Sí Hacer

1. Para mantener brillante la superficie del grifo, límpielo regularmente.
2. Enjuague el grifo con agua limpia y séquelo con un paño de algodón suave.
3. Utilice uno de los siguientes limpiadores para eliminar la suciedad de la superficie:
  - a. Limpiador líquido suave.
  - b. Limpiador de vidrio incoloro y limpiador en polvo que no causen abrasión y se disuelvan completamente.
  - c. Líquido de pulido que no cause abrasión.

### Qué No Hacer

1. Evite el uso de polvos de limpieza, productos químicos de limpieza agresivos, cepillos y trapos ásperos para evitar arañazos y rozaduras.
2. No utilice limpiadores ácidos para limpiar el grifo, ya que pueden causar corrosión en la superficie. Si el grifo entra en contacto con sustancias ácidas dañinas, enjuáguelo inmediatamente con agua.

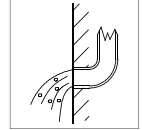

## Herramientas Necesarias:

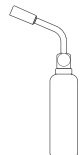
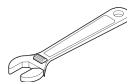
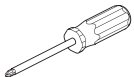

## ◆ Juego de Grifo para Lavabo de Agua Fría y Caliente

### Lista de Accesorios

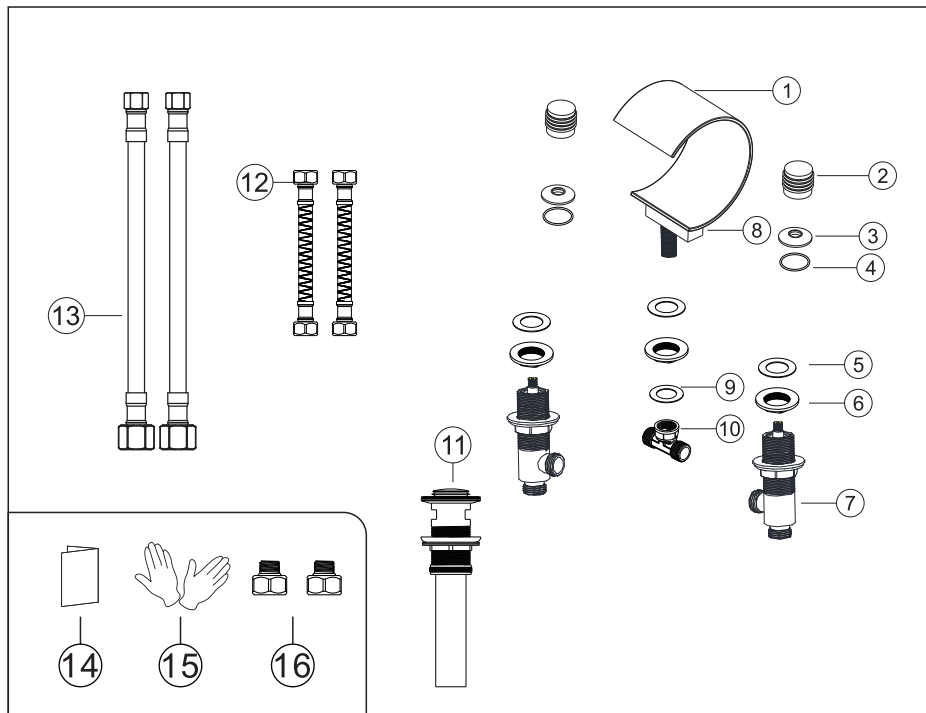

N.º	Nombre de la pieza	Cant.	N.º	Nombre de la pieza	Cant.
1	Cuerpo del grifo	1	9	Junta en T	1
2	Manija	2	10	Tee	1
3	Brida de la manija	2	11	Conjunto de desagüe	1
4	Anillo resistente a la abrasión en forma de O	2	12	Mangueras de conexión	1 par
5	Junta	3	13	Mangueras de agua caliente y fría	1 par
6	Tuerca de fijación	3	14	Manual de instrucciones	1
7	Cuerpo de control de agua	2	15	Guantes	1 par
8	Base del grifo	1	16	Adaptador de manguera (cambio de G9/16 a G1/2)	2

## ◆ Instalación del Grifo de Lavabo

### Paso 1

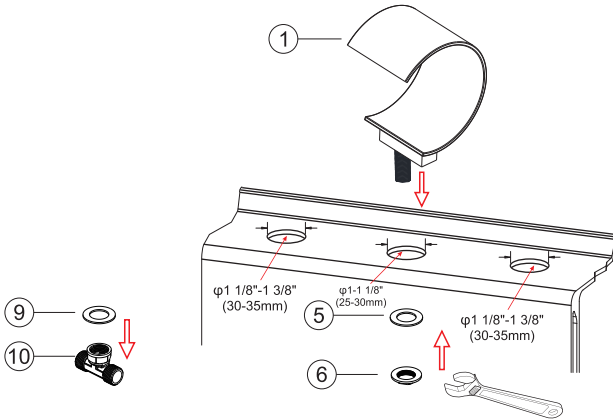

Pase la pieza de latón a través del orificio del grifo del lavabo. Coloque la junta del cuerpo del grifo ⑤ y la tuerca de montaje ⑥ en secuencia sobre la pieza de latón desde debajo del lavabo. Apriete firmemente la tuerca de montaje utilizando una llave. Evite apretar demasiado para no dañar el lavabo o los componentes. Coloque la junta en T ⑨ dentro de la T ⑩ y luego fije la T a la pieza de latón. Asegúrese de que todas las piezas estén correctamente alineadas y conectadas de manera segura.

### Paso 2

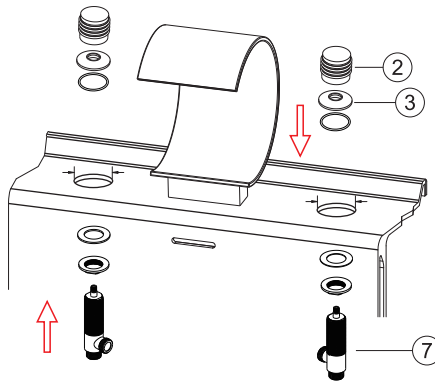

Retire la brida de la manija ③ y colóquela sobre los orificios del grifo del lavabo. Desde debajo del lavabo, conecte el cuerpo de control de agua ⑦ a la brida de la manija alineándolos con los orificios del lavabo. Asegure la conexión apretando los accesorios. Asegúrese de que todos los componentes estén correctamente alineados para evitar fugas. Conecte las manijas al cuerpo de control de agua y apriételas firmemente utilizando las herramientas o tornillos proporcionados. Evite apretar demasiado para no causar daños.

No desarme la válvula por su cuenta, ya que un manejo inadecuado puede provocar fugas o comprometer su funcionalidad.

## ◆ Instalación del Grifo de Lavabo

### Paso 3

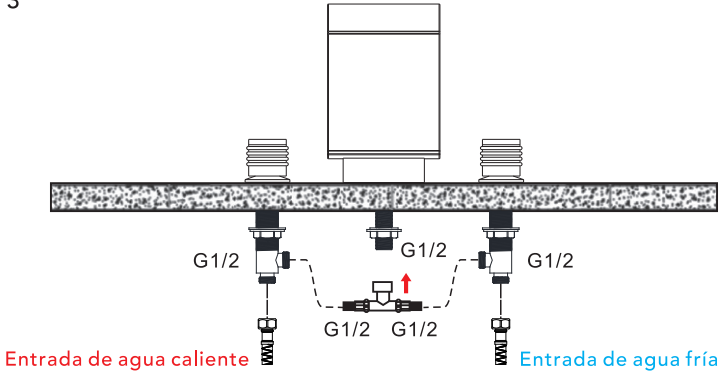

Conecte un extremo de las mangueras de entrada a los cuerpos de control de agua y el otro extremo a la T. Asegúrese de que todas las conexiones estén correctamente alineadas y apriételas firmemente utilizando una llave o a mano, según sea necesario. Utilice la manguera roja para el suministro de agua caliente y la manguera azul para el suministro de agua fría. Verifique nuevamente que cada manguera esté conectada a la fuente de agua correspondiente para evitar configuraciones incorrectas.

### Paso 4

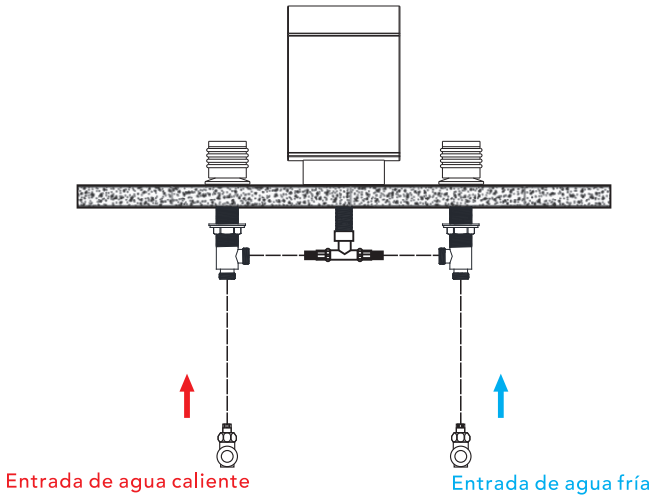

Conecte un extremo de cada manguera a las válvulas de ángulo y el otro extremo al Cuerpo de la Válvula. Conecte la manguera izquierda al suministro de agua caliente (válvula de ángulo) y la manguera derecha al suministro de agua fría (válvula de ángulo). Asegúrese de que todas las conexiones estén correctamente apretadas para evitar fugas.

## ◆ Instalación del Desagüe

### Paso 1

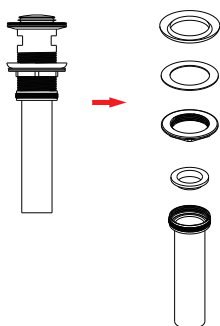

- Desmonte el desagüe comenzando por la parte inferior. Como se muestra en la imagen de la izquierda, retire todos los componentes.

### Paso 2

- Inserte la parte superior del desagüe en el orificio de drenaje del lavabo y, desde la parte inferior hacia arriba, coloque secuencialmente la junta de goma, la arandela y la manga de fijación de latón. Gire la manga de latón hacia la derecha hasta que quede ajustada, pero no apriete en exceso para evitar dañar el lavabo o el desagüe.
- Finalmente, continúe girando y apretando hacia abajo la parte inferior de los componentes del desagüe para completar la instalación.

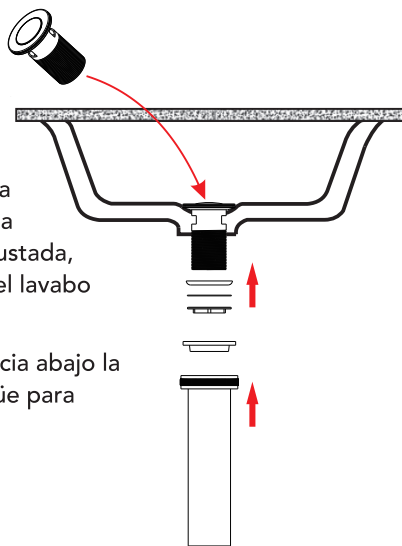

## ◆ Instalación del Desagüe

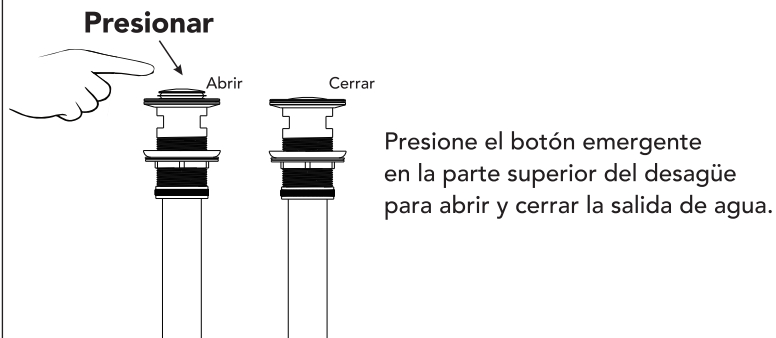

### ⚠ Aviso:

1. Prueba de sellado: Abra el grifo y deje correr el agua durante unos minutos. Observe el desagüe y las conexiones de la tubería de drenaje para detectar posibles fugas. Si encuentra alguna fuga, reajuste la junta y las tuercas hasta lograr un sellado adecuado.
2. Prueba de velocidad de drenaje: Asegúrese de que el agua drene sin problemas, sin bloqueos ni problemas de drenaje lento.
3. Elija el desagüe adecuado: Diferentes lavabos pueden requerir distintos tamaños y tipos de desagües. Asegúrese de que el desagüe que compre sea compatible con su lavabo.