

Basin Faucet Installation Manual

W-294(ES)

Warranty Duration

All components of this faucet system are covered under a lifetime limited warranty, ensuring they are free from defects in material and workmanship for the original purchaser.

Repair and Replacement

If the product shows defects in material or workmanship under normal use and within the warranty period, we will, at our discretion, either repair the product or provide a replacement at no cost to the original purchaser. Please note that proof of purchase (e.g., an invoice) is required when requesting service. The warranty does not cover damages caused by improper installation, misuse, or modifications.

Exclusions

We shall not be responsible for the following cases:

- Damage to the product caused by improper installation, misuse, unauthorized repair or replacement, or abuse (including damage during shipment).
- Damage to the product caused by improper dismantling after installation.
- Damage resulting from abnormal water pressure or impurities in water pipes, which is not covered under this warranty.
- Rust on the product due to insufficient care and maintenance, which is not covered under this warranty.
- Damage caused by natural disasters such as fire, flood, earthquake, lightning storms, etc., which is not covered under this warranty.

I hope this helps! If you have any further questions or concerns, please let me know.

Having Trouble? Contact us.

✉ Email: info@faucetsupport.com

☎ Toll Free: 1-888-969-6880



M2389-H
SFS-1123

CONTENT

Basin Faucet Installation Manual ----- (1-5)

CONTENIDO

Manual de Instalación del Grifo para Lavabo ----- (6-10)

Prior to Installation

1. Ensure that all necessary parts are available by referring to the diagram and parts list.
2. Ensure that your basin matches the kitchen faucet size.
3. Do not disassemble the main faucet body, as it has been properly installed and tested before delivery from the factory.
4. Turn off the hot and cold water supply before starting the installation.
5. To prevent the faucet from clogging, flush the water pipes before installation.
6. After completing the installation, check all joints and connections for leaks.

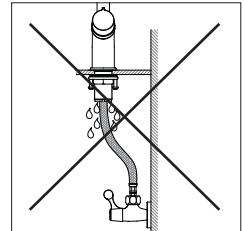
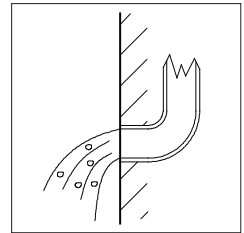
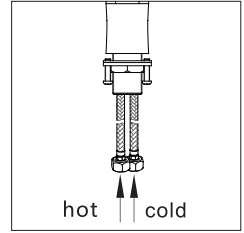

Standard Part List

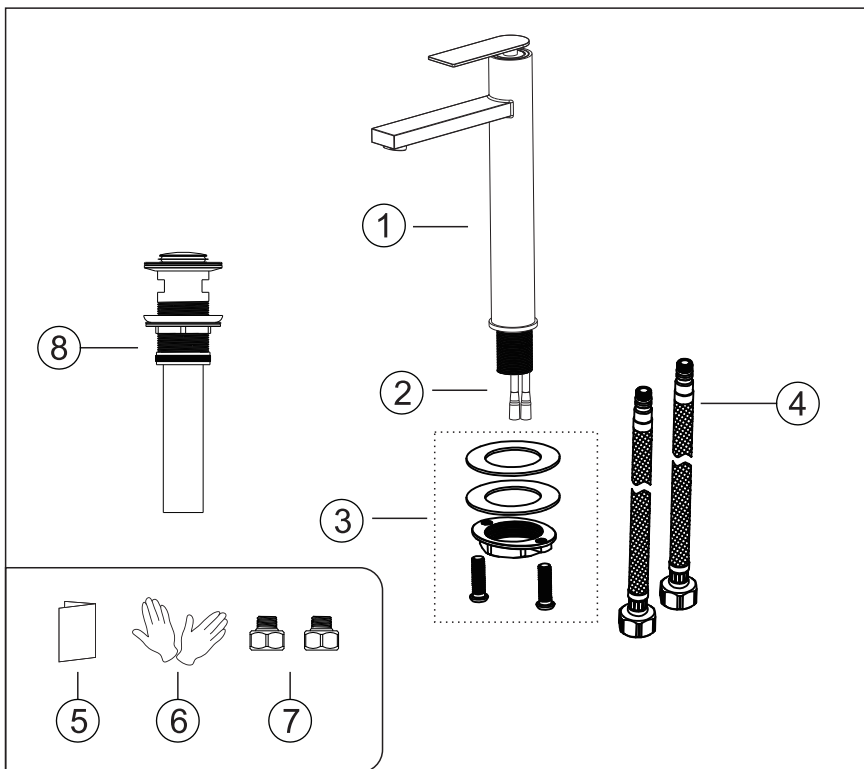

NO.	Part Name	Qty
1	Faucet body	1
2	Extension copper pipe	2
3	Tailpiece nut assembly	1 set
4	Hot and cold inlet pipes	1
5	Installation manual	1
6	Gloves	2
7	Hose adapter change G9/16 to G1/2	2
8	Drain	1

Installation Step

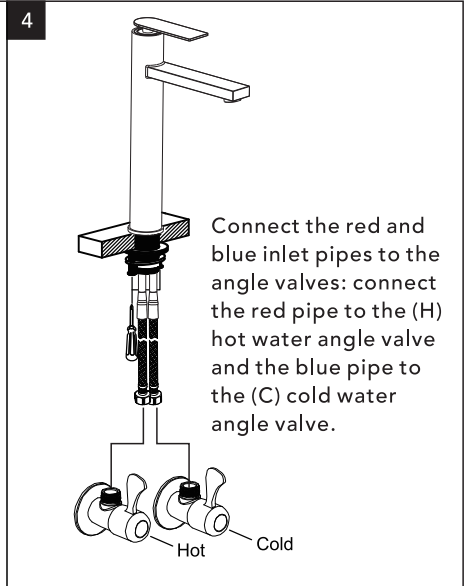
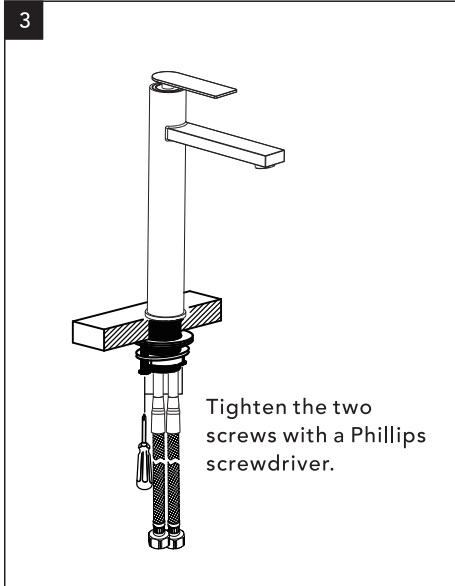
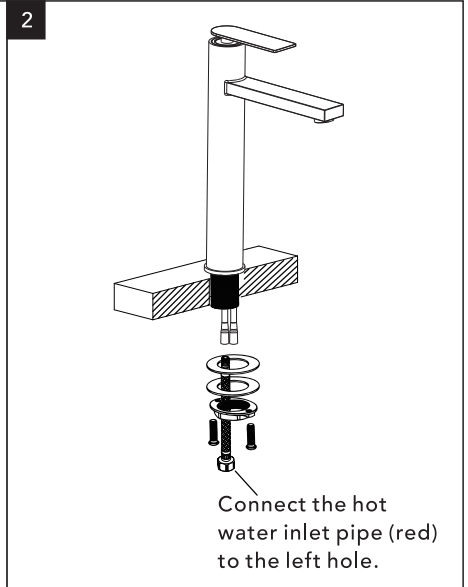
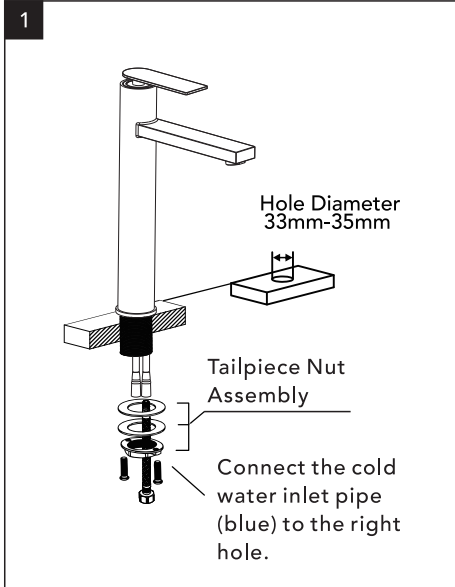

Drain Installation

Step1

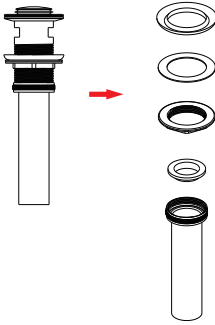

- Disassemble the drain starting from the bottom part. As shown in the left image, remove all components.

Step2

- Insert the top of the drain into the basin drain hole, and from the bottom upwards, sequentially fit the rubber gasket, washer, and fixing brass sleeve. Rotate the brass sleeve to the right until it is tight, but do not over-tighten to avoid damaging the basin or the drain.

- Finally, continue to rotate and tighten the lower part of the drain components downward to complete the drain installation.

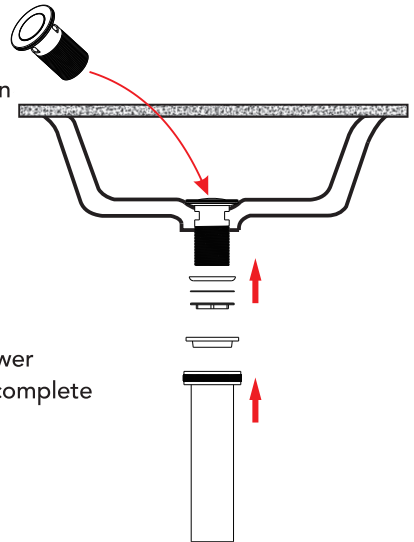

Drain Installation

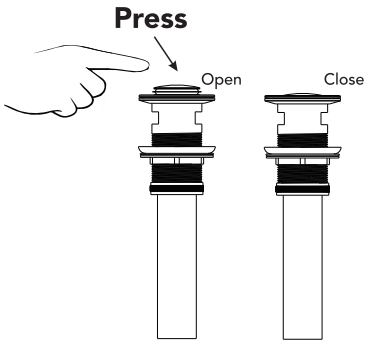

Press the pop-up button on top of the drain to open and close the drain outlet.



Notice:

1. **Sealing Test:** Turn on the faucet and let the water run for a few minutes. Observe the drain and the drainage pipe connections for any leaks. If you find any leaks, readjust the tightness of the gasket and nuts.
2. **Drainage Speed Test:** Ensure that the water drains smoothly without any blockages or slow drainage issues.
3. **Choose the Right Drain:** Different basins may require different sizes and types of drains. Make sure the drain you purchase matches your basin.

Antes de la instalación

1. Asegúrese de tener todas las piezas necesarias verificando el diagrama y la lista de piezas.
2. Verifique si su lavabo es compatible con el tamaño del grifo del lavabo.
3. No desmonte el cuerpo principal del grifo, ya que ha sido instalado y ajustado correctamente y con precisión antes de su entrega desde la fábrica.
4. Cierre los suministros de agua caliente y fría antes de comenzar.
5. Para evitar que el grifo se obstruya, enjuague la tubería de agua antes de la instalación.
6. Al finalizar la instalación, revise todas las uniones y conexiones para detectar posibles fugas.

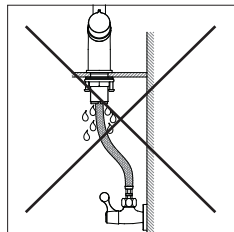
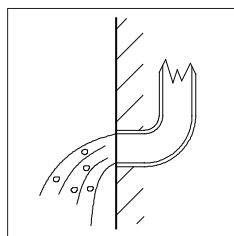
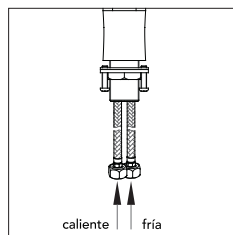

Lista estándar de piezas

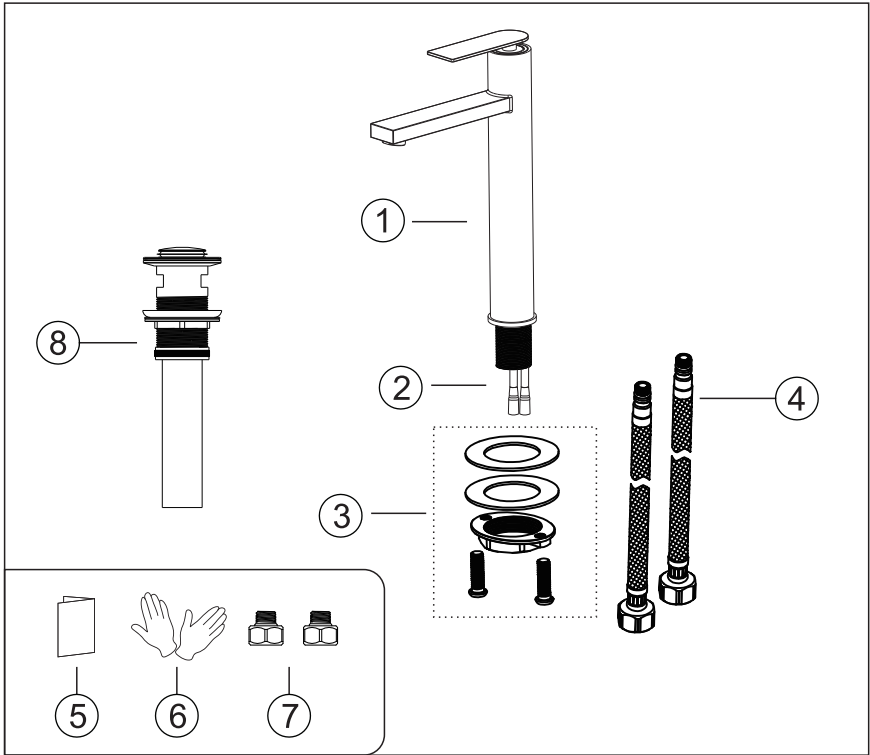

N.º	Nombre de la pieza	Cant.
1	Cuerpo del grifo	1
2	Tubo de extensión de cobre	2
3	Ensamblaje de la tuerca del manguito	1 juego
4	Tuberías de entrada de agua caliente y fría	1
5	Manual de instalación	1
6	Guantes	2
7	Adaptador de manguera para cambiar de G9/16 a G1/2	2
8	Desagüe	1

Paso de instalación

1

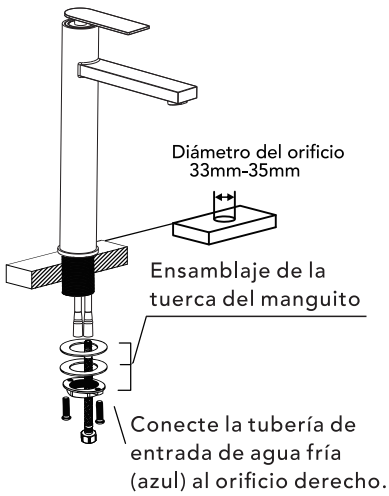

2

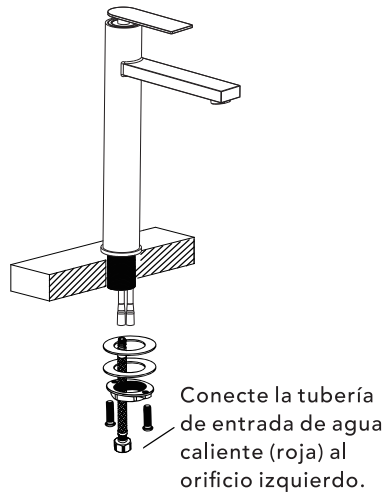

3

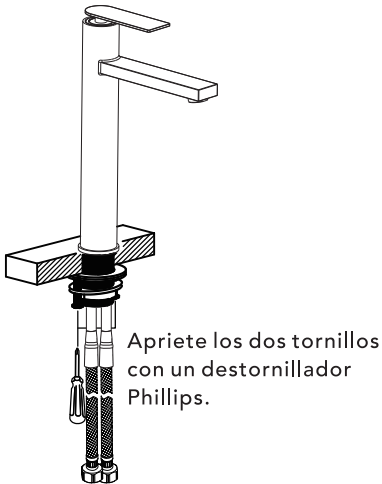

4

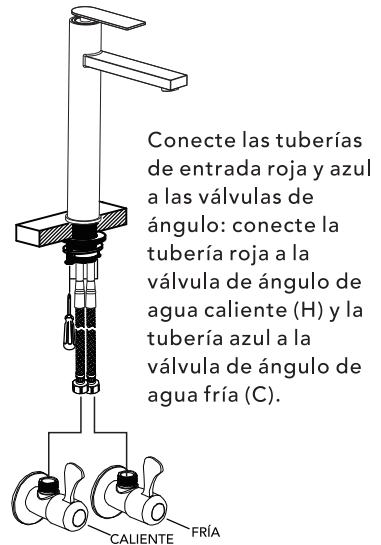

Instalación del desagüe

Paso 1

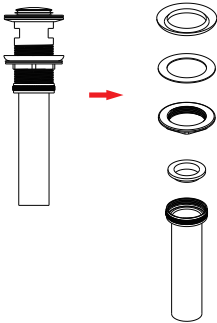

- Desmonte el desagüe comenzando por la parte inferior. Como se muestra en la imagen de la izquierda, retire todos los componentes.

Paso 2

- Inserte la parte superior del desagüe en el orificio de drenaje del lavabo y, desde la parte inferior hacia arriba, coloque secuencialmente la junta de goma, la arandela y la manga de fijación de latón. Gire la manga de latón hacia la derecha hasta que quede ajustada, pero no apriete en exceso para evitar dañar el lavabo o el desagüe.
- Finalmente, continúe girando y apretando hacia abajo la parte inferior de los componentes del desagüe para completar la instalación.

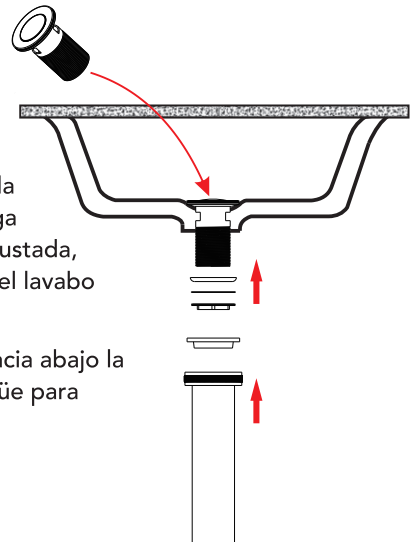

Instalación del desagüe

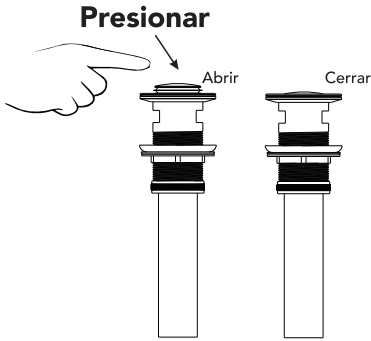

Presione el botón emergente en la parte superior del desagüe para abrir y cerrar la salida de agua.



Aviso:

1. Prueba de sellado: Abra el grifo y deje correr el agua durante unos minutos. Observe el desagüe y las conexiones de la tubería de drenaje para detectar posibles fugas. Si encuentra alguna fuga, reajuste la junta y las tuercas hasta lograr un sellado adecuado.
2. Prueba de velocidad de drenaje: Asegúrese de que el agua drene sin problemas, sin bloqueos ni problemas de drenaje lento.
3. Elija el desagüe adecuado: Diferentes lavabos pueden requerir distintos tamaños y tipos de desagües. Asegúrese de que el desagüe que compre sea compatible con su lavabo.