

INSTALLATION MANUAL



SFS1102

IMPORTANT NOTICE

- ▲ Ensure the pipes are clear and flush or blow out debris before installation to prevent blockages.
- Please read this manual carefully before installation.
- Ensure all parts are included before starting the assembly.
- For replacement parts, please contact us using the contact information in the footer.

LIMITED LIFETIME WARRANTY

EVERSTEIN, a brand committed to the highest standards of quality and craftsmanship, provides a Limited Lifetime Warranty for its faucets. This warranty is applicable to the original purchaser and covers defects in material or manufacturing workmanship, proof of purchase will be required in the case of a claim.

For manufacture defects, EVERSTEIN will, at its option, (1) replace the defective part or product free of charge, (2) refund the original purchase price of the product (valid for 30 days from the date of delivery).

EVERSTEIN recommends installation by a licensed professional plumber. EVERSTEIN is not responsible for any damage or product failure caused by improper installation, misuse or failure to use a licensed professional.

WARRANTY COVERAGE EXCLUSIONS

This warranty does not cover defects or damage caused by the use of non-EVERSTEIN original parts. Furthermore, any damage resulting from faulty installation, product abuse, improper use, or the use of abrasive cleaners or solvents is not covered by this warranty. Labor charges and/or damage incurred during installation, repair, or replacement are also not the responsibility of EVERSTEIN.

LIMITATIONS OF LIABILITY

Except as required by law, this warranty replaces all other warranties, conditions, and guarantees, whether expressed or implied, statutory or otherwise, including but not limited to merchantability or suitability. In certain states, provinces, and countries, the exclusion or limitation of incidental or consequential damages may not apply.

RESPONSIBILITIES OF OTHERS

Inspecting the unit prior to installation is the responsibility of the installer or building contractor who acts on behalf of the user. They are responsible for ensuring the unit is free of defect or damage. In the event of a problem, the unit must not be installed. EVERSTEIN is not responsible for failures or damage that could have been discovered, repaired, or avoided by proper inspection and testing prior to installation.

Damage occurring in transit is the responsibility of the carrier. The user or installer MUST open the crate and inspect the unit for damage when it is delivered. If damage is discovered, it must be reported immediately to the EVERSTEIN and the carrier in writing.

WARRANTY SERVICE NOTE

When requesting warranty, be sure to have the following:

- Copy of original invoice
- Date of installation
- Description and pictures of defect
- Model number or description of model

To obtain warranty service and replacement part, please contact EVERSTEIN Customer Service Team. EVERSTEIN will determine whether to repair or replace your product, issue a refund.

CONTENT

1. Installation Instructions for Pressure-balanced Shower Faucet --- (1-6)

CONTENIDO

**1. Instrucciones de Instalación para el Grifo de Ducha con
Válvula de Equilibrio de Presión** ----- (7-12)

◆ Installation and Maintenance Matters

1. Check the accessories list to verify that all parts are complete in this package.
2. Do not disassemble the main body by yourself.
3. Connect inlet pipes to supply valves.
4. Make sure inlet pipes and supply valves have no impurities and are cleaned, with no impurities in the pipeline.
5. After installation, check all joints for leakages.
6. Do not leave the rain shower system exposed to a severely corrosive environment.

Do's

1. In order to keep the mixer surface bright, please clean the mixer regularly.
2. Rinse the faucet with clean water and wipe it with a soft cotton cloth.
3. Use one of the following cleaners to remove dirt from the surface: a. Mild liquid cleaner. b. Colorless glass cleaner and powder cleaner that do not cause abrasion and can be dissolved completely. c. Polish liquid that does not cause abrasion.

Don'ts

- a. Avoid using cleaning powder, harsh cleaning chemicals, brushes and coarse cloth to prevent scratching and friction.
- b. Do not use acid cleaners to clean the faucet as they may cause surface corrosion of the faucet. If the faucet is exposed to harmful acid substances, please rinse it immediately with water.

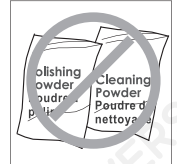
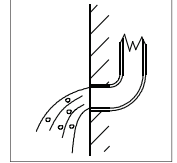
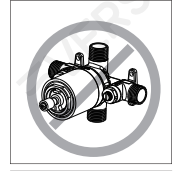

Tools Needed:

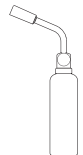
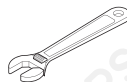
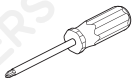

◆ Two-function Pressure-balanced Shower Faucet

Accessories List

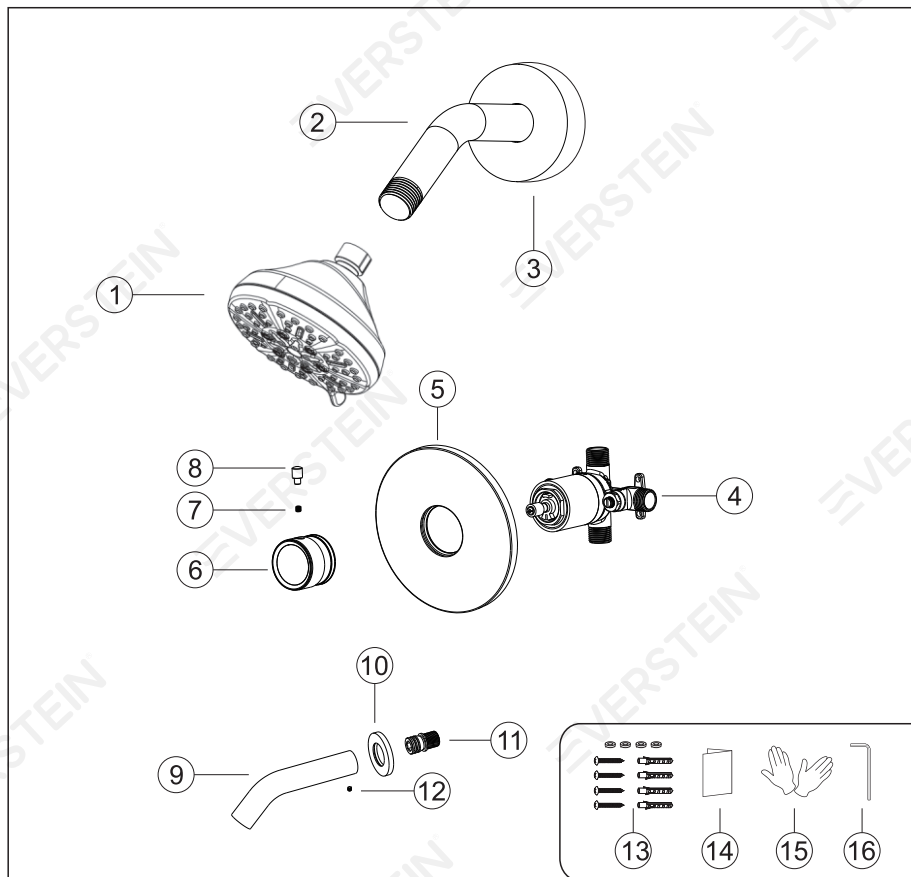

No.	Part name	Qty	No.	Part name	Qty
1	Shower head	1	9	Bathtub spout	1
2	Shower arm	1	10	Bathtub spout flange	1
3	Shower arm flange	1	11	Bathtub spout connector	1
4	Main body	1	12	Bathtub spout screw	1
5	Deck plate	1	13	Main body spare parts	1 set
6	Handle	1	14	Instruction manual	1
7	Handle screw	1	15	Gloves	2
8	Handle cap	1	16	Handle wrench	1

◆ Essential Dimensions & Water Pipe Line

Unit: mm/inch

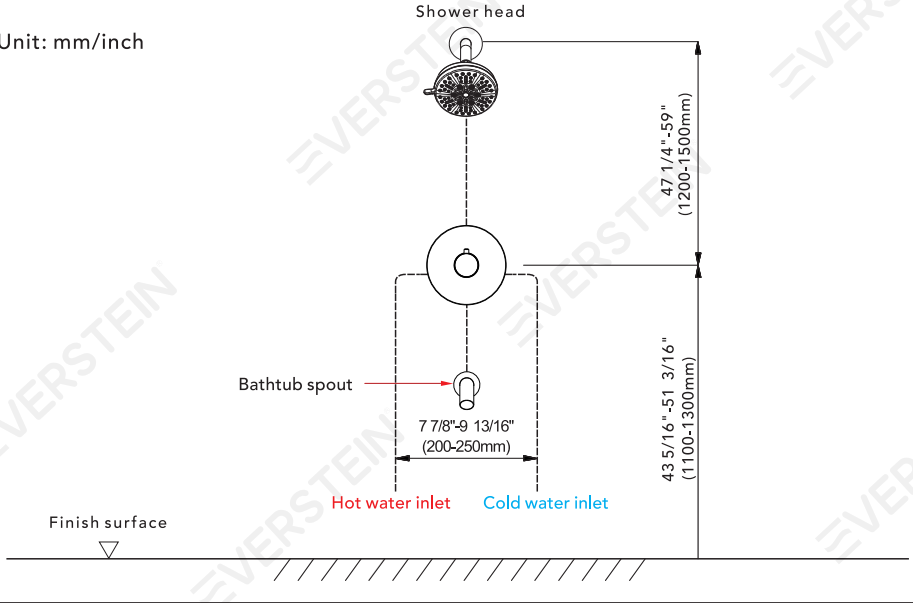

◆ The Installation Depth of Shower Arm and Bathtub Spout

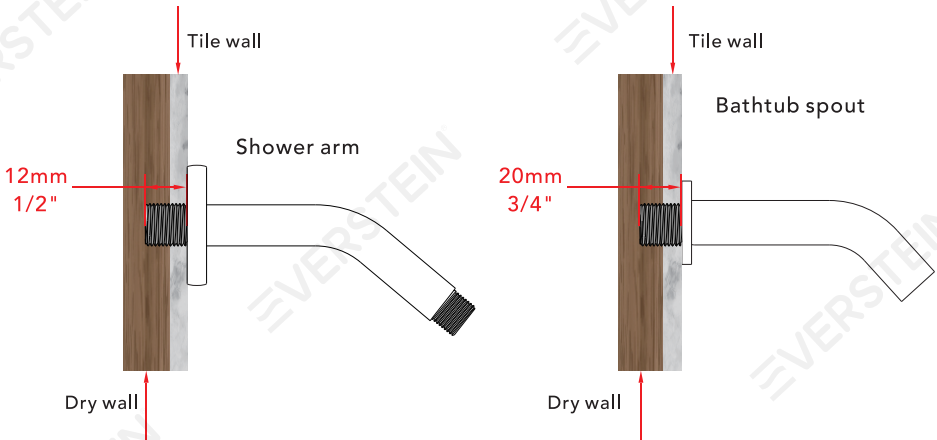

The thickness of the tile must be calculated for installation.

Connector size of male thread: USA: 1/2"-14NPT, Canada: 1/2"-14NPT, Europe: G1/2".

◆ Bathtub Spout Installation Steps

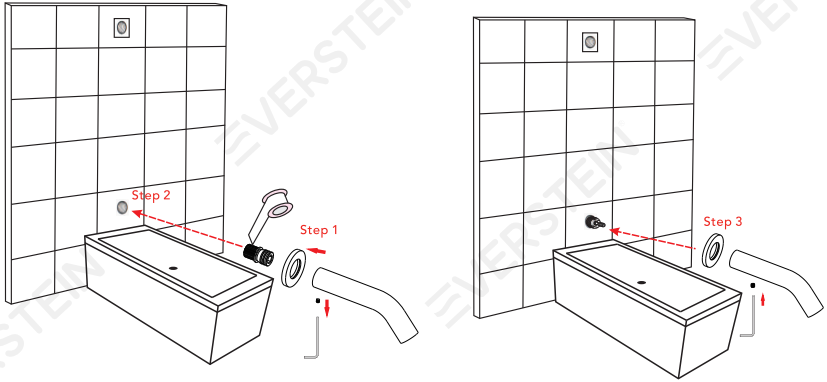

Step 1: Loosen the screw beneath the water outlet tap and remove the bathtub spout connector. Wrap PTFE tape around the connector to ensure a watertight seal.

Step 2: Insert the bathtub spout connector into the pre-drilled hole in the wall and securely tighten it using a hex screwdriver.

Step 3: Attach the bathtub spout by inserting its end into the pre-installed wall fitting, then firmly retighten the screw. Ensure that the water outlet is aligned directly downward.

◆ Installation of the Shower Arm and Shower Head

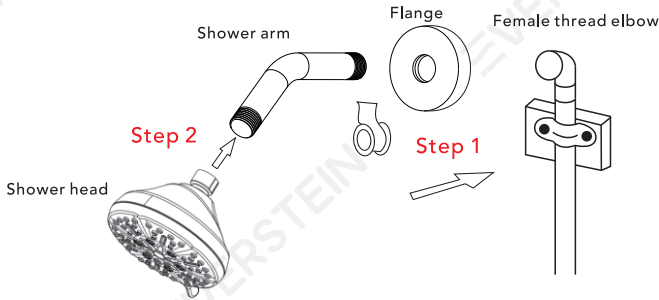

1. To prevent potential damage, attach the shower arm to the flange before screwing it into the riser connection. As shown in the diagram, wrap sealing tape around the external threads on one end of the shower arm, then connect it securely to the water supply pipe in the wall.

2. Refer to the diagram to properly attach the shower head to the shower arm.

3. Avoid over-tightening the shower head, as it is designed with a 360° swivel connection.

◆ Installation Depth of Main Body

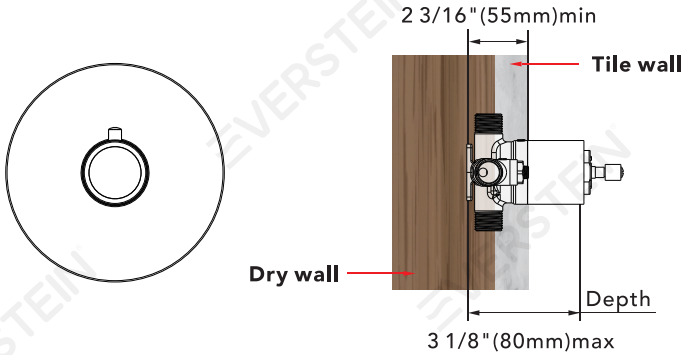

- Notice:** 1. The installation depth of the main body should be no less than 2 3/16" (55mm) and no more than 3 1/8" (80mm), including the thickness of the tile. Otherwise, the deck plate cannot be installed.
2. The opening size of ceramic tile shall be smaller than the deck plate size.

◆ Piping Instructions Before Tiling

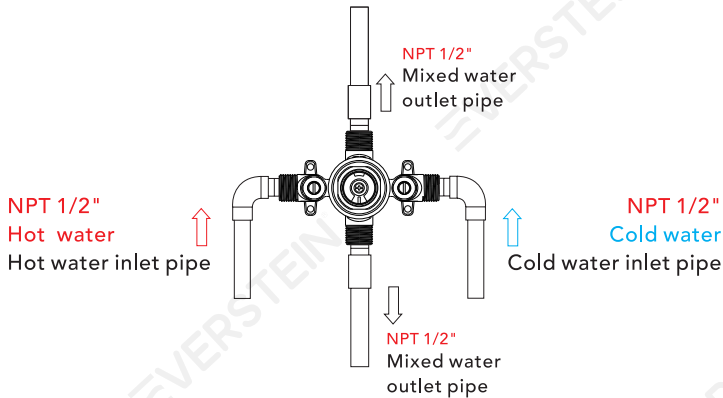

1. As shown in the diagram, the inlet and outlet pipes should be pre-buried. Please ensure the correct orientation of the pre-buried main body during installation.
2. Before tiling, turn on the water to test whether the left and right inlet pipes are securely connected and free of leaks. Then, adjust the flow switch to the "on" position to check for leaks in the mixed outlet pipes.

◆ Main Body Valve Installation

Step1

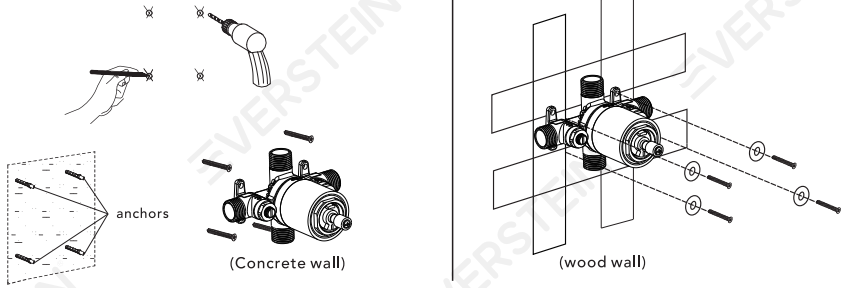

1. Make marks according to the size of the main body valve, and then drill anchors into the wall (concrete wall).
 2. Lock the main body to wood directly with screws (wood wall).
 3. When installing the main body, please mark the UP side up and do not install it upside down.
- ▲ Please note that the level meter should be parallel to the wall; otherwise, the deck plate cannot be installed.

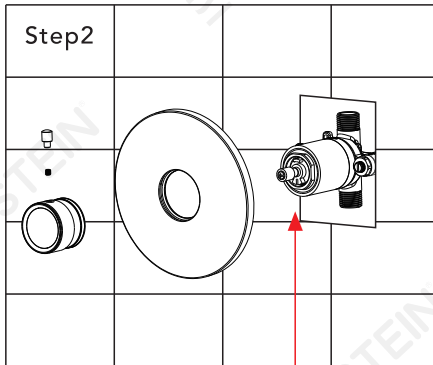

Do not remove the white wear ring; otherwise, the handwheel will be damaged.

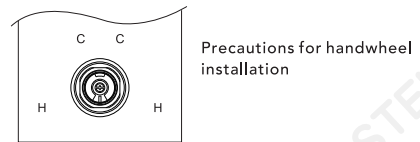
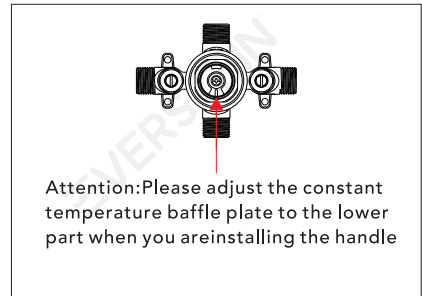

1. Use Main body spare parts and to fixed Main body on the wall and then install deck plate.
2. Please fix the main body to the wall install deck plate ,water diverter screw and water diverter cap step by step.
3. Install the handle with the screw and handle cap.

◆ Instalación y cuestiones de mantenimiento

1. Verifique la lista de accesorios para comprobar que todas las partes están completas en este paquete.
2. No desmonte el cuerpo principal por sí mismo.
3. Conecte las tuberías de entrada a las válvulas de suministro.
4. Asegúrese de que las tuberías de entrada y las válvulas de suministro no tengan impurezas y estén limpias, sin impurezas en la tubería.
5. Después de la instalación, verifique todas las uniones para detectar fugas.
6. No deje el sistema de ducha tipo lluvia expuesto a un ambiente severamente corrosivo.

Hacer

1. En para mantener la superficie de la batidora brillante, limpie el mezclador regularmente.
2. Inse el grifo con agua limpia y límpielo con un suave ropa de algodón.
3. Utilice uno de los siguientes limpiadores para eliminar la suciedad de la superficie: a. Limpiador líquido suave. b. Limpiador de vidrio incoloro y limpiador en polvo que no causen abrasión y que se puedan disolver completamente. c. Líquido pulidor que no cause abrasión.

No es decir

- A. Valte con polvo de limpieza, productos químicos de limpieza duros, cepillos y tela gruesa para evitar rasgar y fricción.
- B. No use limpiadores de ácidos para limpiar el grifo, ya que pueden causar corrosión superficial del grifo. Si el grifo está expuesto a sustancias ácidas dañinas, enjuague inmediatamente con agua.

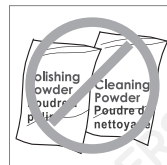
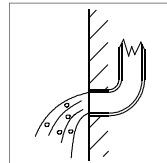
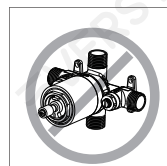

HERRAMIENTAS NECESARIAS:

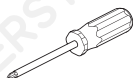

◆ Grifo de ducha equilibrado a presión de dos funciones

Lista de accesorios

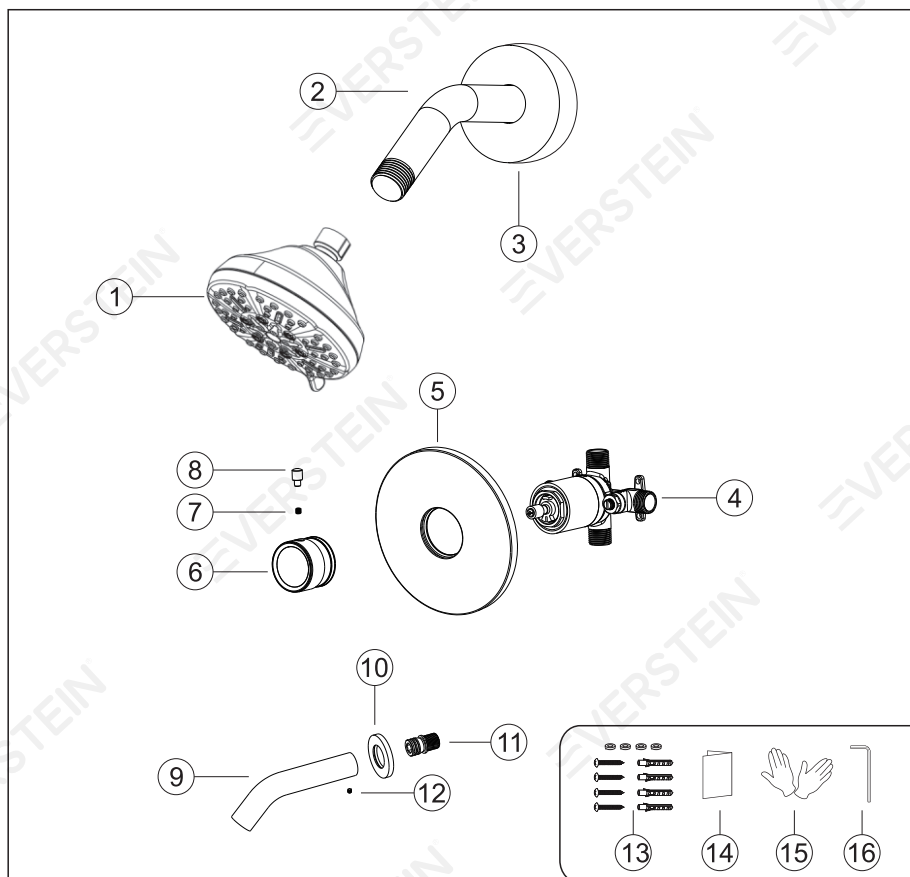

N.º	Nombre de la pieza	Cant	N.º	Nombre de la pieza	Cant
1	Cabezal de ducha	1	9	Salida de bañera	1
2	Brazo de ducha	1	10	Brida de la salida de bañera	1
3	Brida del brazo de ducha	1	11	Conector de la salida de bañera	1
4	Cuerpo principal	1	12	Tornillo de la salida de bañera	1
5	Placa de cubierta	1	13	Piezas de repuesto del cuerpo principal	1 set
6	Manija	1	14	Manual de instrucciones	1
7	Tornillo de la manija	1	15	Guantes	2
8	Tapa de la manija	1	16	Llave para la manija	1

◆ Dimensiones esenciales y línea de tubería de agua

Unidad: mm/pulgada

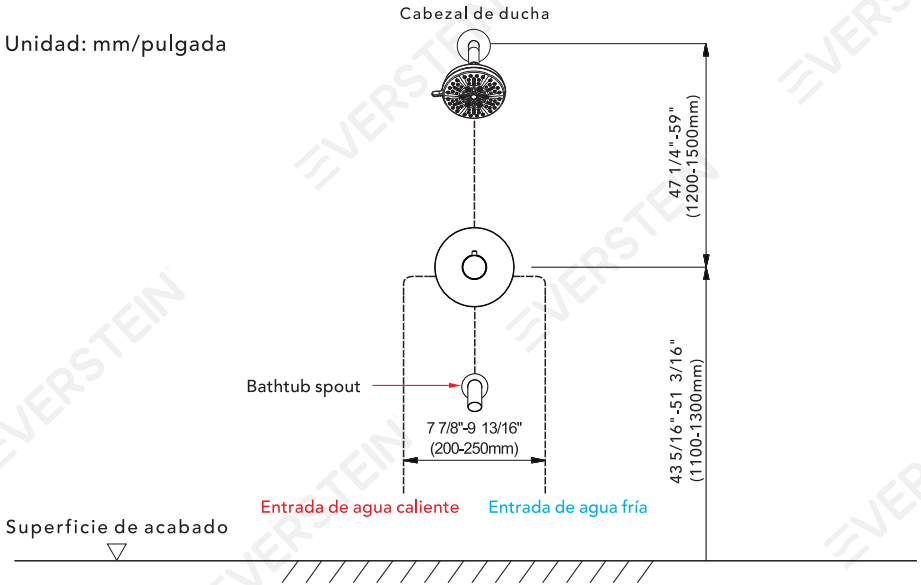

◆ La profundidad de instalación del brazo de ducha y la salida de bañera

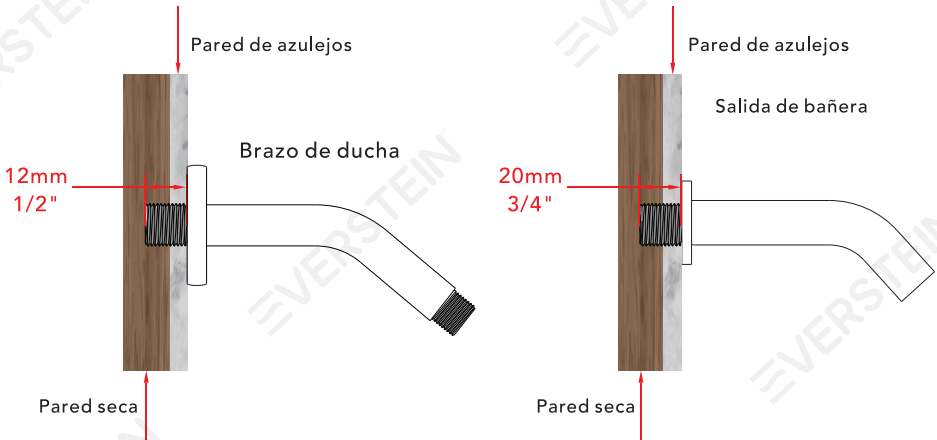

El grosor del azulejo debe calcularse para la instalación. Tamaño del conector de rosca macho:
 EE.UU.: 1/2"-14NPT Canadá: 1/2"-14NPT Europa: G1/2".

◆ Pasos de instalación de la salida de bañera

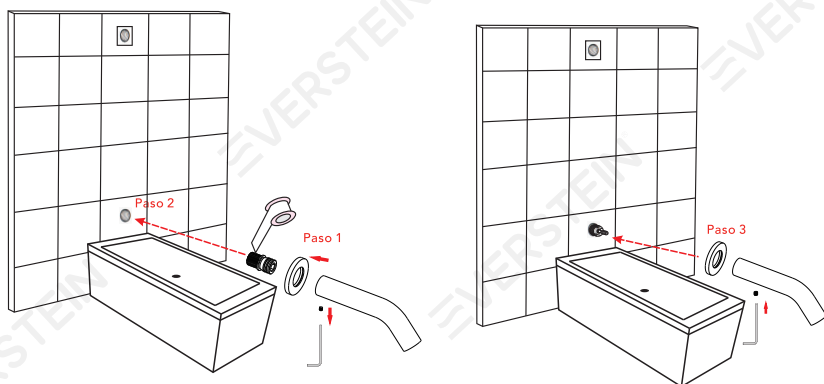

Paso 1: Afloje los dos tornillos debajo del grifo de salida de agua y retire el conector de la salida de bañera. Envuelva el conector con cinta de PTFE.

Paso 2: Coloque el conector de la salida de bañera en el orificio previamente perforado en la pared y ajústelo utilizando un destornillador hexagonal.

Paso 3: Inserte el extremo del conector de la salida de bañera en el conector que ya está instalado en la pared y vuelva a apretar los tornillos. Asegúrese de que la salida quede orientada directamente hacia abajo.

◆ Instalación del brazo de ducha y el cabezal de ducha

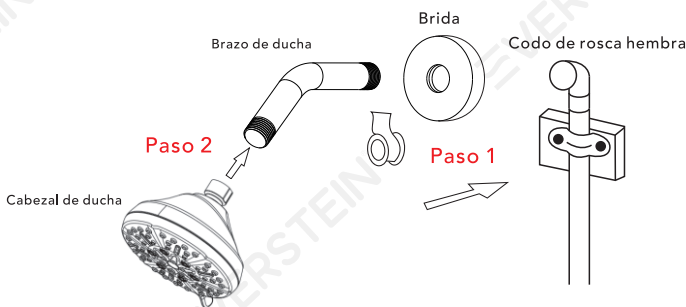

1. Fije el brazo de ducha a la brida antes de atornillarlo a la conexión del tubo ascendente para evitar daños. Como se muestra en el diagrama, envuelva cinta de sellado alrededor de las roscas externas en un extremo del brazo de ducha y luego conéctelo a la tubería de agua en la pared.

2. Como se muestra en el diagrama, conecte el cabezal de ducha al brazo de ducha.

3. Evite apretar demasiado el cabezal de ducha, ya que cuenta con una conexión giratoria de 360°.

◆ Profundidad de instalación del cuerpo principal

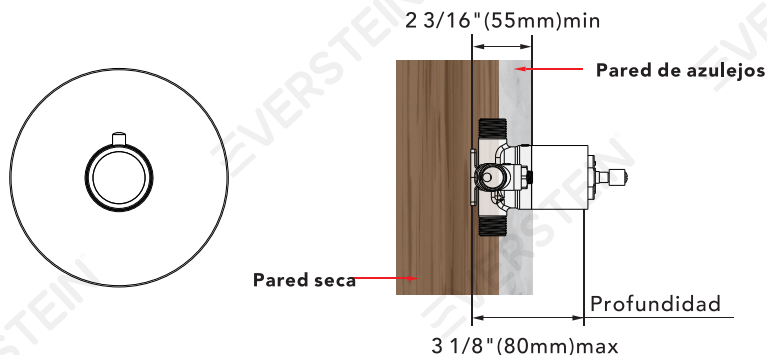

- Aviso:** 1. La profundidad de instalación del cuerpo principal debe ser de al menos 2 3/16" (55 mm) y no más de 3 1/8" (80 mm), incluyendo el grosor del azulejo. De lo contrario, la placa de cubierta no podrá instalarse.
2. El tamaño de la abertura del azulejo cerámico debe ser menor que el tamaño de la placa de cubierta.

◆ Instrucciones para la tubería antes de colocar los azulejos

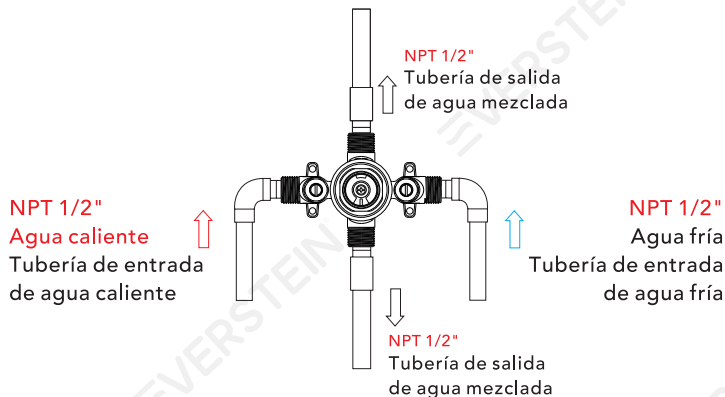

1. Como se muestra en el diagrama, las tuberías de entrada y salida deben estar preinstaladas. Por favor, asegúrese de la orientación correcta del cuerpo principal preinstalado durante la instalación.
2. Antes de colocar los azulejos, abra el agua para comprobar si las tuberías de entrada izquierda y derecha están bien conectadas y sin fugas. Luego, ajuste el interruptor de flujo a la posición "encendido" para verificar si hay fugas en las tuberías de salida de agua mezclada.

◆ Instalación de la válvula del cuerpo principal

Paso 1

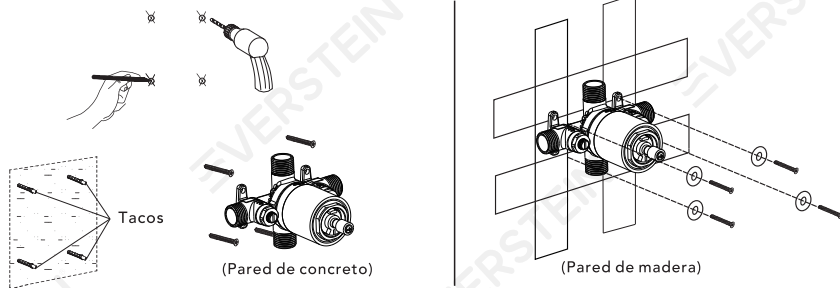

1. Haga marcas de acuerdo con el tamaño de la válvula del cuerpo principal y luego inserte los tacos en la pared (pared de concreto).
 2. Fije directamente el cuerpo principal a la madera con tornillos (pared de madera).
 3. Al instalar el cuerpo principal, asegúrese de que el lado marcado como UP esté hacia arriba y no lo instale al revés.
- ▲ Por favor, tenga en cuenta que el nivelador debe estar paralelo a la pared; de lo contrario, la placa de cubierta no podrá instalarse.

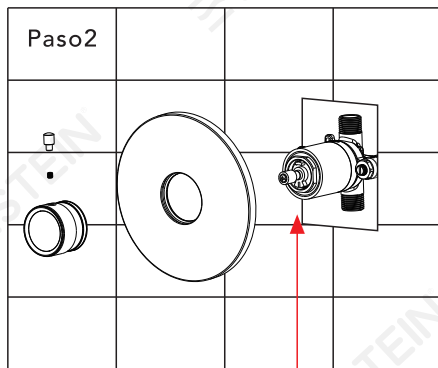

No retire el anillo blanco de desgaste; de lo contrario, el volante se dañará.

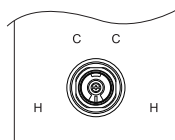
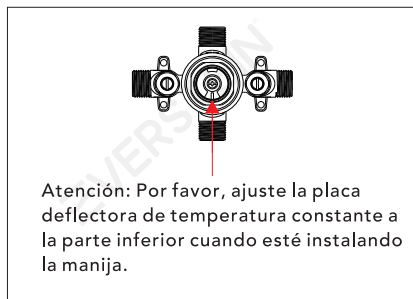

1. Use las piezas de repuesto del cuerpo principal para fijar el cuerpo principal a la pared y luego instale la placa de cubierta.
2. Fije el cuerpo principal a la pared e instale la placa de cubierta, el tornillo del desviador de agua y la tapa del desviador de agua paso a paso.
3. Instale la manija con el tornillo y la tapa de la manija.