

INSTALLATION MANUAL



SFS1025

IMPORTANT NOTICE

- ▲ Ensure the pipes are clear and flush or blow out debris before installation to prevent blockages.
- Please read this manual carefully before installation.
- Ensure all parts are included before starting the assembly.
- For replacement parts, please contact us using the contact information in the footer.

LIFETIME LIMITED WARRANTY

EVERSTEIN, a brand committed to the highest standards of quality and craftsmanship, provides a Lifetime Limited Warranty for its shower systems. This warranty is applicable to the original purchaser and covers defects in material or manufacturing workmanship, proof of purchase will be required in the case of a claim.

For manufacture defects, EVERSTEIN will, at its option, (1) replace the defective part or product free of charge, (2) refund the original purchase price of the product (valid for 30 days from the date of delivery).

EVERSTEIN recommends installation by a licensed professional plumber. EVERSTEIN is not responsible for any damage or product failure caused by improper installation, misuse or failure to use a licensed professional.

WARRANTY COVERAGE EXCLUSIONS:

This warranty does not cover defects or damage caused by the use of non-EVERSTEIN original parts. Furthermore, any damage resulting from faulty installation, product abuse, improper use, or the use of abrasive cleaners or solvents is not covered by this warranty. Labor charges and/or damage incurred during installation, repair, or replacement are also not the responsibility of EVERSTEIN.

LIMITATIONS OF LIABILITY:

Except as required by law, this warranty replaces all other warranties, conditions, and guarantees, whether expressed or implied, statutory or otherwise, including but not limited to merchantability or suitability. In certain states, provinces, and countries, the exclusion or limitation of incidental or consequential damages may not apply.

RESPONSIBILITIES OF OTHERS

Inspecting the unit prior to installation is the responsibility of the installer or building contractor who acts on behalf of the user. They are responsible for ensuring the unit is free of defect or damage. In the event of a problem, the unit must not be installed. EVERSTEIN is not responsible for failures or damage that could have been discovered, repaired, or avoided by proper inspection and testing prior to installation.

Damage occurring in transit is the responsibility of the carrier. The user or installer MUST open the crate and inspect the unit for damage when it is delivered. If damage is discovered, it must be reported immediately to the EVERSTEIN and the carrier in writing.

WARRANTY SERVICE NOTE

When requesting warranty, be sure to have the following:

- Copy of original invoice
- Date of installation
- Description and pictures of defect
- Model number or description of model

To obtain warranty service and replacement part, please contact EVERSTEIN Customer Service Team. EVERSTEIN will determine whether to repair or replace your product, issue a refund.

CONTENT

1. Installation Manual for LED Thermostatic Shower Set -----(1-12)

CONTENIDO

1. Instrucciones de instalación del conjunto de ducha
termostática LED -----(13-24)

◆ Installation and Maintenance Matters

1. Check the accessories list to verify that all parts are complete in this package.
2. Do not disassemble the main body by yourself.
3. Connect inlet pipes to supply valves.
4. Make sure inlet pipes and supply valves have no impurities and are cleaned, with no impurities in the pipeline.
5. After installation, check all joints for leakages.
6. Do not leave the rain shower system exposed to a severely corrosive environment.

Do's

1. In order to keep the mixer surface bright, please clean the mixer regularly.
2. Rinse the faucet with clean water and wipe it with a soft cotton cloth.
3. Use one of the following cleaners to remove dirt from the surface:
a. Mild liquid cleaner.
b. Colorless glass cleaner and powder cleaner that do not cause abrasion and can be dissolved completely.
c. Polish liquid that does not cause abrasion.

Don'ts

- a. Avoid using cleaning powder, harsh cleaning chemicals, brushes and coarse cloth to prevent scratching and friction.
- b. Do not use acid cleaners to clean the faucet as they may cause surface corrosion of the faucet. If the faucet is exposed to harmful acid substances, please rinse it immediately with water.

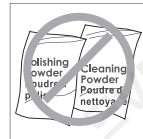
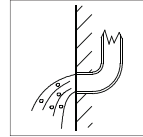
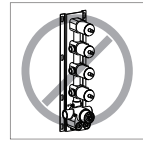

Tools Needed:

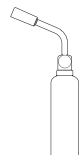
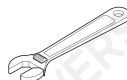
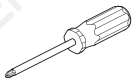

◆ 4-Function Split Thermostatic Shower Faucet Set

Accessories List

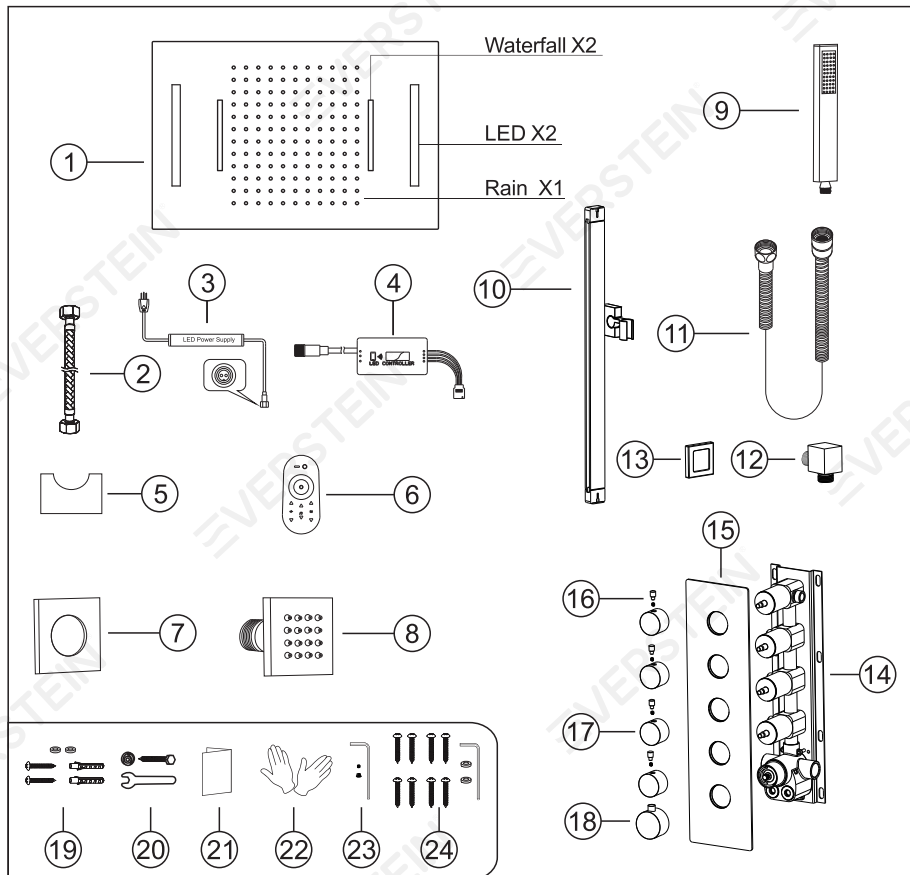

No.	Part name	Qty	No.	Part name	Qty
1	Shower head body	1	13	Cup	1
2	Shower head hose	2	14	Main body	1
3	Water proof power supply	1	15	Deck plate	1
4	Wifi Controller	1	16	Water diverter rod	4
5	Controller pedestal	1	17	Water diverter	4
6	LED Controller	1	18	Handle	1
7	Body jet cover	6	19	Main body spare parts	8
8	Body jet	6	20	Lifting rod parts	1set
9	Shower hand	1	21	Instruction manual	1
10	Lifting rod	1	22	Gloves	2
11	Shower hose	1	23	Handle parts	1set
12	Connector	1	24	Shower head screw package	1set

◆ Essential Dimensions & Water Pipe Line

Unit: mm/inch

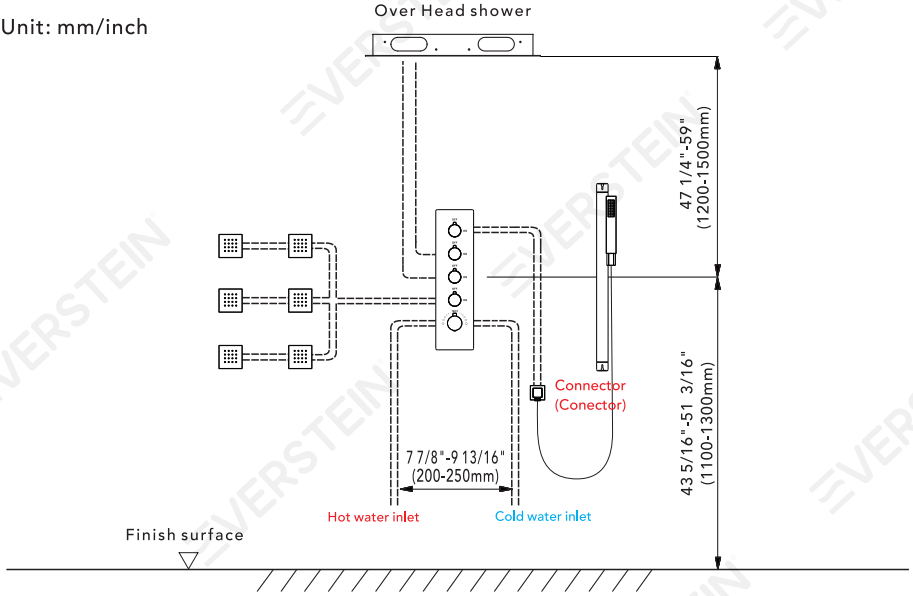

◆ The Installation Depth of Shower Holder and Body Jet

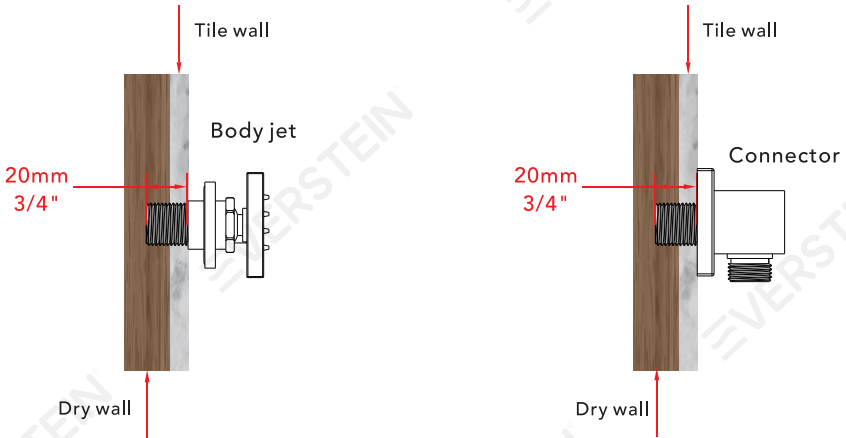

The thickness of the tile must be calculated for installation.

Connector size of male thread: USA: 1/2"-14NPT, Canada: 1/2"-14NPT, Europe: G1/2".

◆ Installation Depth of Main Body

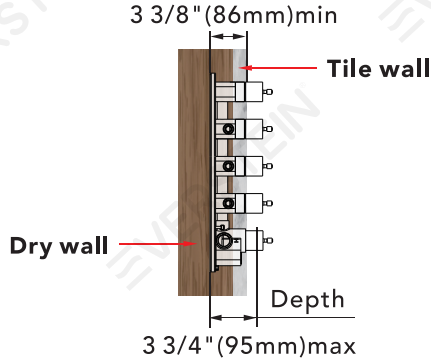
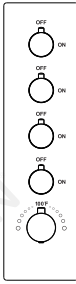

- Notice:**
1. The installation depth of the main body should be no less than 3 3/8" (86mm) and no more than 3 3/4" (95mm), including the thickness of the tile. Otherwise, the deck plate cannot be installed.
 2. The opening size of ceramic tile shall be smaller than the deck plate size.

◆ Piping Instructions Before Tiling

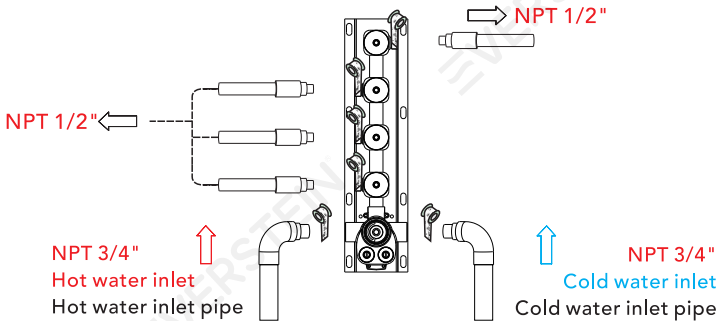

1. As shown in the figure, the inlet and outlet pipes are pre-buried. Please pay attention to the correct direction when installing the pre-buried main body.
2. Before tiling, turn on the water to test whether the left and right inlet pipes are tightly connected without leakage. Then, adjust the flow switch to the "on" position to check for leaks in the mixed outlet pipes.

◆ Main Body Valve Installation

Step1

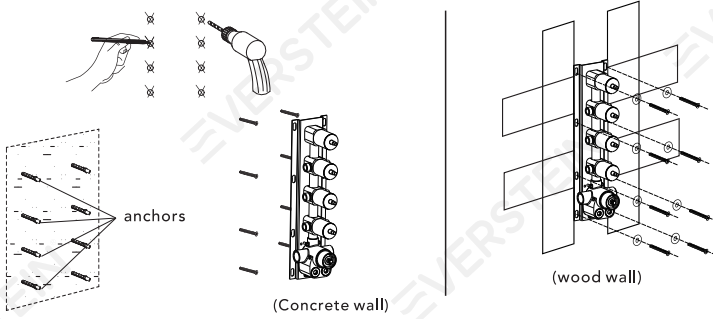

1. Make marks according to the dimensions of the main body valve, then drill anchors into the wall (for a concrete wall).

2. Secure the main body directly to a wood wall using screws.

3. When installing the main body, ensure the "UP" side is facing upwards; do not install it upside down.

▲ Please note: The level meter should be parallel to the wall; otherwise, the deck plate cannot be installed properly.

Step2

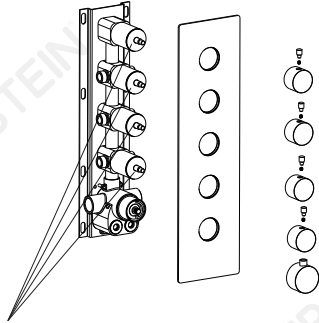

Precautions for Handwheel Installation

※ 1. The line can't be misplaced; it should be kept in line. Otherwise, the water temperature of 100°F or 38°C will not be correct.



※ 2. Please ensure that the plastic locating ring (A) and handwheel locating pin (B) are kept in the same line with 100°F or 38°C. Otherwise, the water temperature will be incorrect.

Do not remove the white wear ring; otherwise, the handwheel will be damaged.

Water flow control: clockwise Turn-down and stop, anti-clockwise turn-up to max

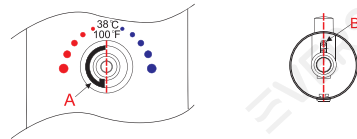

1. Please install the deck plate, water diverters, and water diverter rods step by step.

2. Install the handle with the screw and handle cap.

◆ Lifting Rod Installation

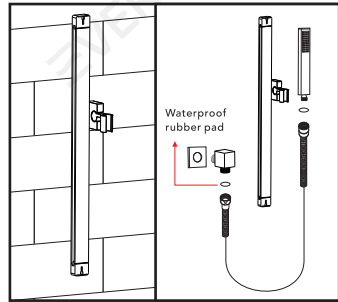
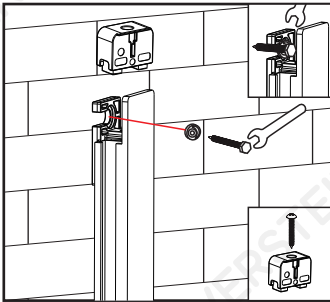
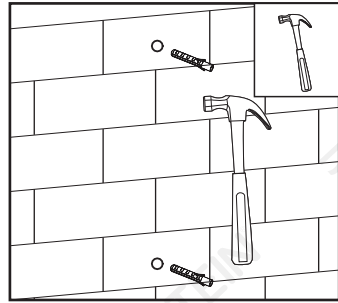
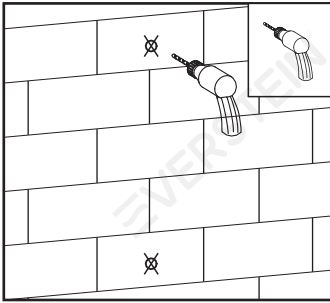
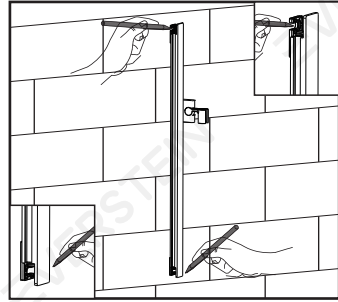
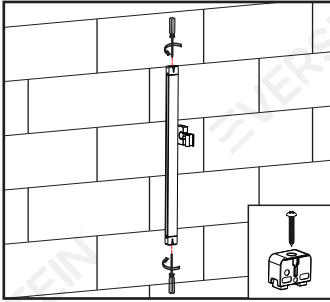

1. Firstly, remove the upper and lower screws of the sliding rod.
2. Use a pen to mark the size of the turning hole.
3. Hammer in the rubber particles with a hammer.
4. Use a wrench to twist the screws and then use a screwdriver to install the product.
5. Once completed, the installation is finished.

◆ Body Jets Installation

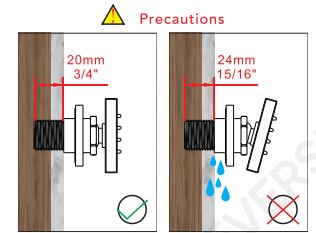
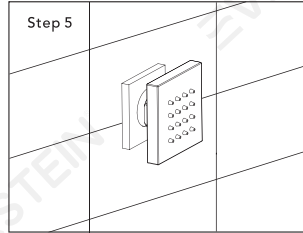
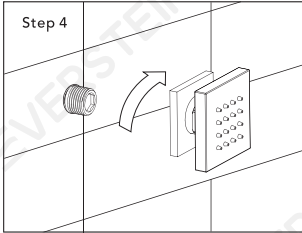
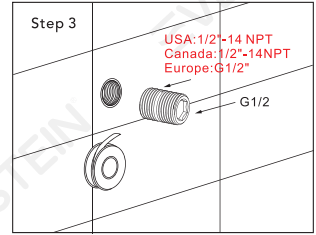
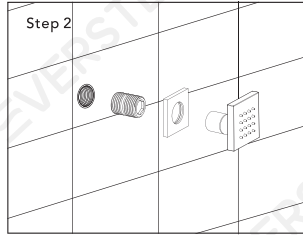
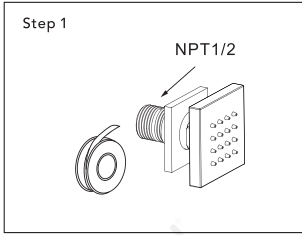

Step 3: Wrap the threaded pipe of NPT1/2 with Teflon tape and screw it into the wall.

Step 4: Screw the massage body jet onto the wall.

Step 5: The installation is complete

◆ Plumbing Layout of Shower Head

①

USA: 1/2"-14NPT
Canada: 1/2NPT
Europe: G1/2"

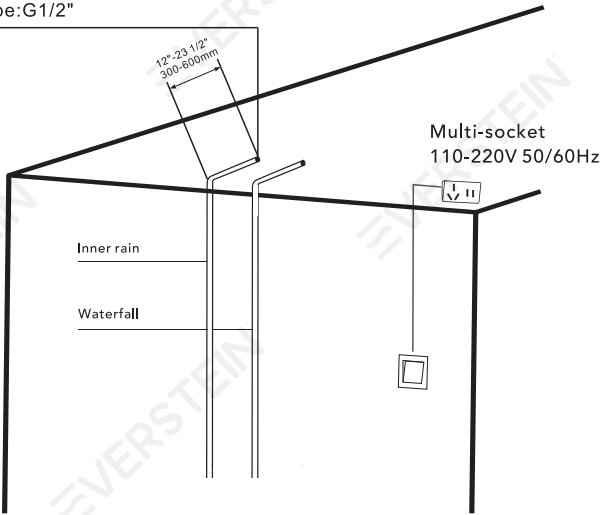

Install the power switch in the appropriate position, lay out the water pipeline, and connect it to the main body.

◆ Holes on Ceiling

②

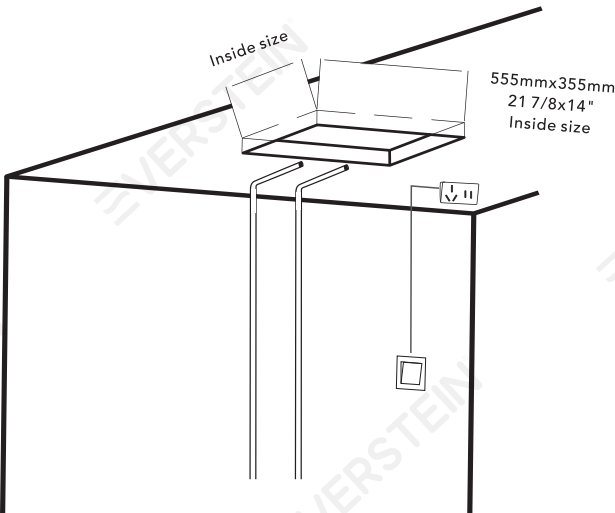

◆ Shower Head Exploded View

③

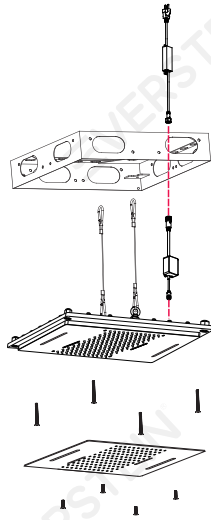

Waterproof power supply

Stainless steel fix frame

WiFi connection

Shower head body

Decorative shower panel

According to the mark (Remove/Install) on the top of the shower head panel, unscrew the decorative shower panel, shower head body, and fix frame respectively.

◆ Fix Frame Installation

④

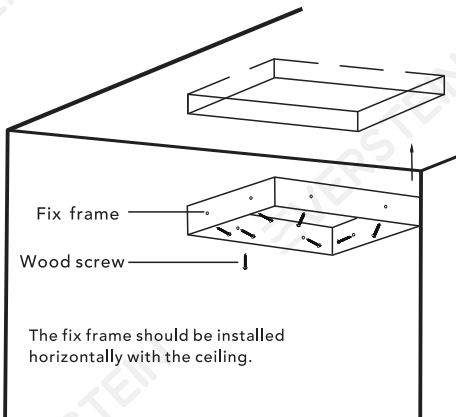

Fix frame

Wood screw

The fix frame should be installed horizontally with the ceiling.

Fasten the fix frame to the wooden frame with screws

◆ Layout for Power

⑤

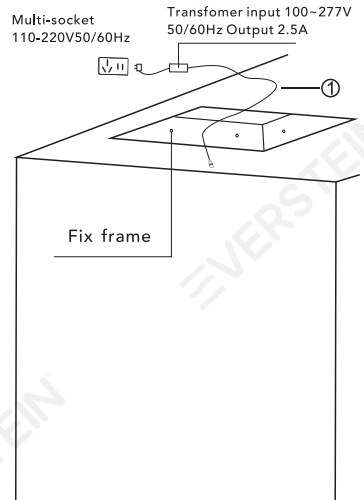

Multi-socket
110-220V/50/60Hz

Transformer input 100-277V
50/60Hz Output 2.5A

Fix frame

◆ LED (Single Line) Connection

⑥

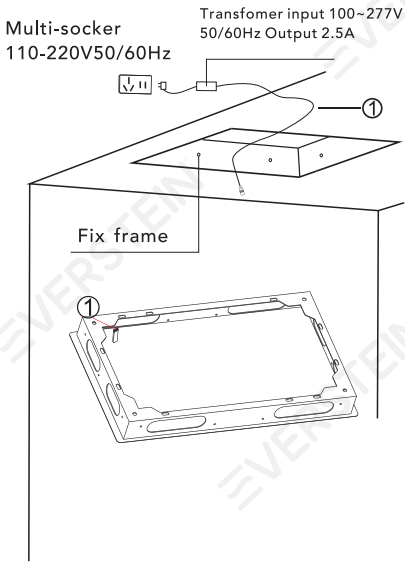

① To attach the WiFi controller, wrap it with adhesive tape to prevent it from falling off.

② To connect the power supply and WiFi

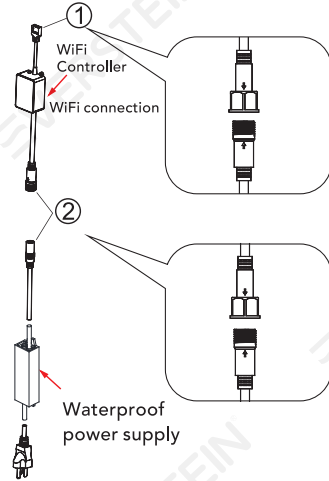

◆ Shower Head Body Installation

⑦

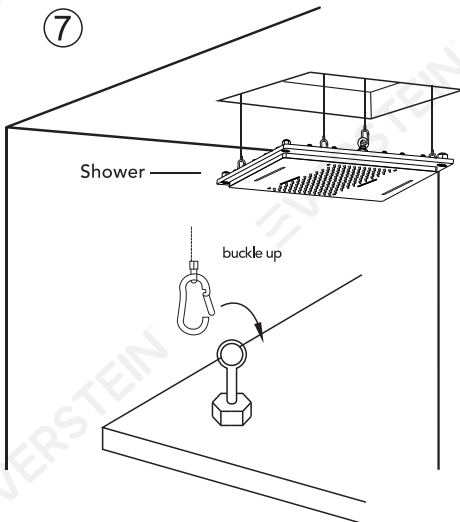

◆ Layout for Water Pipe

⑧

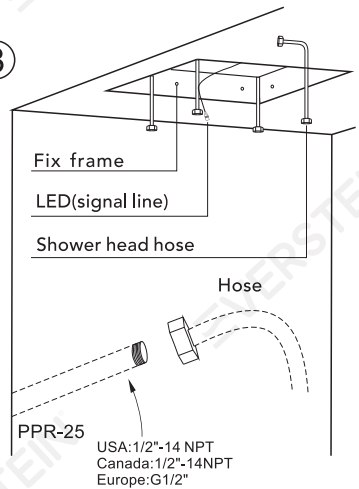

Connect one end of the corrugated pipe to the embedded PPR water pipe and the other end to the water inlet pipe on the back of the shower head.

◆ Water Inlet Pipe Connection

9

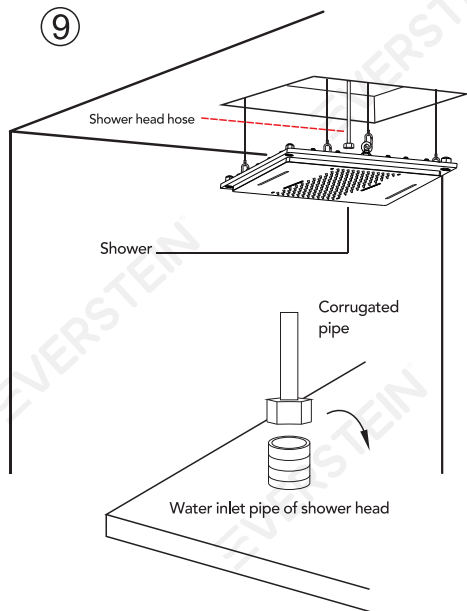

◆ Water Testing

10

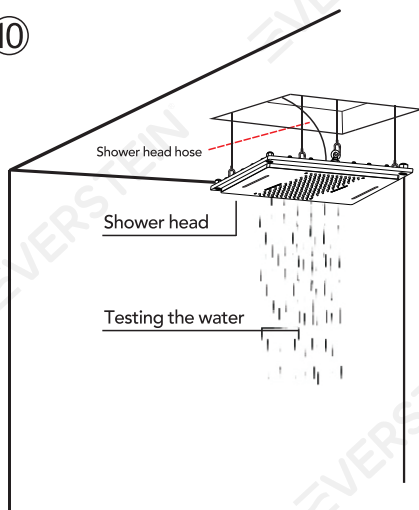

◆ Shower Head Installation

11

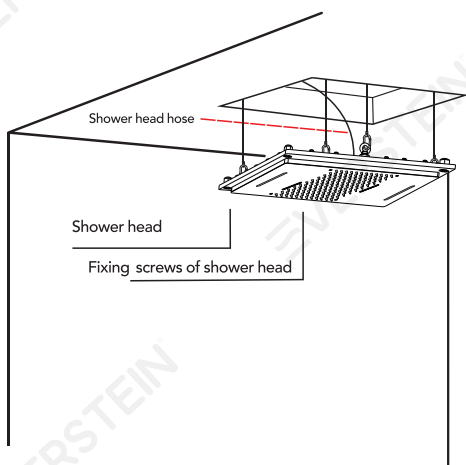

◆ Decorative Shower Panel Installation

12

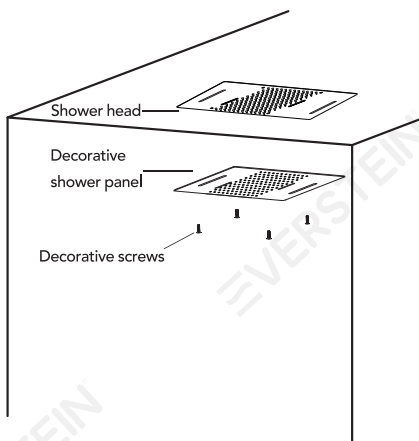

◆ LED Touch Remote Instruction

The touch remote has 9 touch keys, each of which functions as follows:

Controller connections shown:

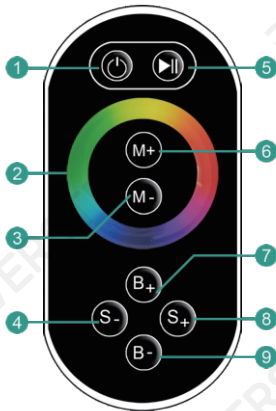

- ① Turn ON/OFF
 - ⑤ Mode Switch
 - ② Color Touch Ring
 - ③/⑥ Color Temperature adjusting
 - ④/⑧ Dynamic Speed adjusting
 - ⑦/⑨ Dynamic Brightness adjusting
- Mode:

NO.	FUNCTION	REMOTE
1	Static red	Brightness is adjustable. speed is unadjustable.
2	Static green	
3	Static blue	
4	R G B Jumping	
5	Static blue-green	
6	Static yellow	
7	Static white	
8	Static purple	Brightness is adjustable Speed is adjustable
9	R G B Gradual	
10	7-Colors Jumping	
11	7-Colors Gradual	

2. Power supply management:

The remote will enter standby mode (untouchable state) if pressed for more than 20 seconds. If this occurs, please slightly shake it once and the remote will return to normal working state (touchable state).

3. Indicator light instruction:

3.1. When the PWR indicator light is bright, the remote is either idle or sending a signal; when the PWR light is off, it will enter standby mode.

3.2. When RF is bright, it means the remote is sending signal; off means there is no signal sending.

Remarks:

1. This product should be commissioned and installed by qualified personnel.
2. This product cannot be waterproof; it needs to be protected from sun and rain. If installed outdoors, please use a waterproof box.
3. Good heat dissipation conditions will extend the life of the LED controller. Please install the product in a well-ventilated environment
4. Please do not install or use such products in lightning, thunder, strong magnetic or high voltage applications.
5. Please check whether the output voltage of the LED power supply used meets the product voltage range requirements.
6. The diameter of the wire used must be sufficient to support the connected LED luminaire, and ensure that the wiring is secure to avoid the wire overheating or poor contact triggering an accident.
7. Before power-on debugging, ensure that all wiring is correct to avoid damage to the luminaire due to wiring errors.

◆ Instalación y cuestiones de mantenimiento

1. Verifique la lista de accesorios para comprobar que todas las partes están completas en este paquete.
2. No desmonte el cuerpo principal por sí mismo.
3. Conecte las tuberías de entrada a las válvulas de suministro.
4. Asegúrese de que las tuberías de entrada y las válvulas de suministro no tengan impurezas y estén limpias, sin impurezas en la tubería.
5. Después de la instalación, verifique todas las uniones para detectar fugas.
6. No deje el sistema de ducha tipo lluvia expuesto a un ambiente severamente corrosivo.

Hacer

1. En para mantener la superficie de la batidora brillante, limpie el mezclador regularmente.
2. Inse el grifo con agua limpia y límpielo con un suave ropa de algodón.
3. Utilice uno de los siguientes limpiadores para eliminar la suciedad de la superficie: a. Limpiador líquido suave. b. Limpiador de vidrio incoloro y limpiador en polvo que no causen abrasión y que se puedan disolver completamente. c. Líquido pulidor que no cause abrasión.

No es decir

- A. Valte con polvo de limpieza, productos químicos de limpieza duros, cepillos y tela gruesa para evitar rasgar y fricción.
- B. No use limpiadores de ácidos para limpiar el grifo, ya que pueden causar corrosión superficial del grifo. Si el grifo está expuesto a sustancias ácidas dañinas, enjuague inmediatamente con agua.

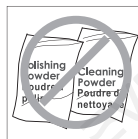
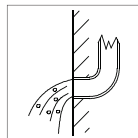
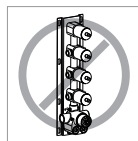

HERRAMIENTAS NECESARIAS:

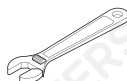
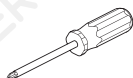

◆ Juego de grifo de ducha termostático de 4 funciones con divisor

Lista de accesorios

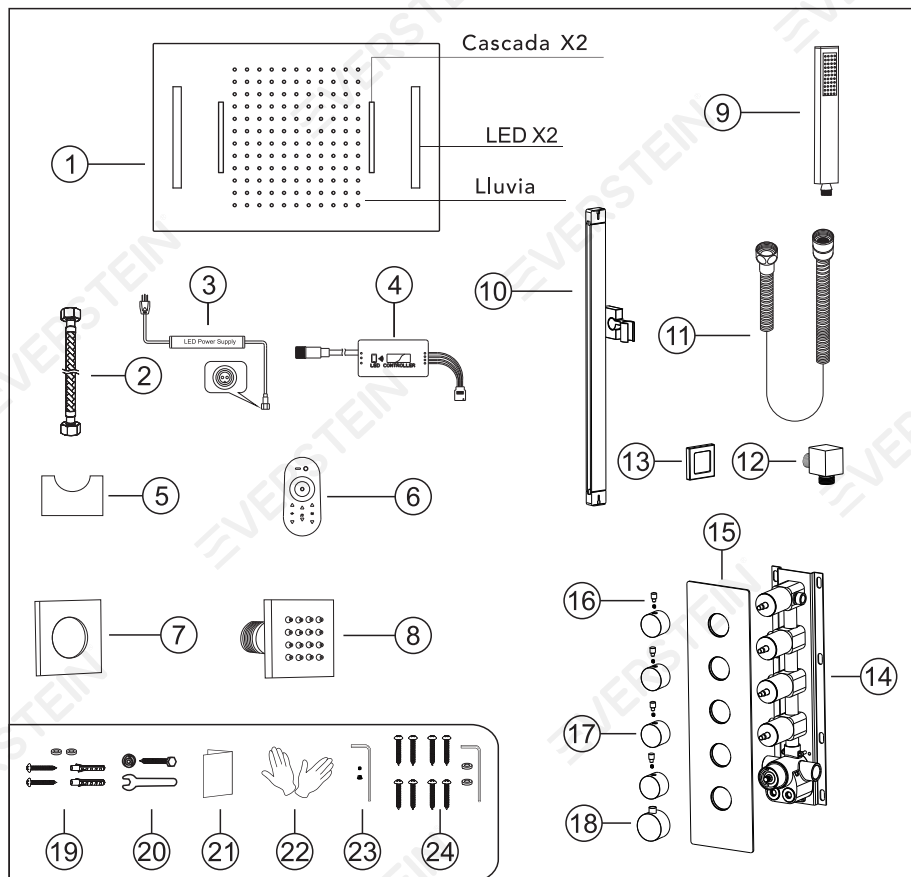

N.º	Nombre de la pieza	Cant.	N.º	Nombre de la pieza	Cant.
1	Cuerpo del cabezal de ducha	1	13	Taza	1
2	Manguera del cabezal de ducha	2	14	Cuerpo principal	1
3	Fuente de alimentación a prueba de agua	1	15	Placa de cubierta	1
4	Controlador WiFi	1	16	Varilla desviadora de agua	4
5	Pedestal del controlador	1	17	Desviador de agua	4
6	Controlador LED	1	18	Manija	1
7	Cubierta del chorro corporal	6	19	Repuestos del cuerpo principal	8
8	Chorro corporal	6	20	Piezas de la barra de elevación	1 set
9	Ducha de mano	1	21	Manual de instrucciones	1
10	Barra de elevación	1	22	Guantes	2
11	Manguera de ducha	1	23	Piezas de la manija	1 set
12	Conector	1	24	Paquete de tornillos del cabezal de ducha	1 set

◆ Dimensiones esenciales & línea de tubería de agua

Unidad: mm/pulgada

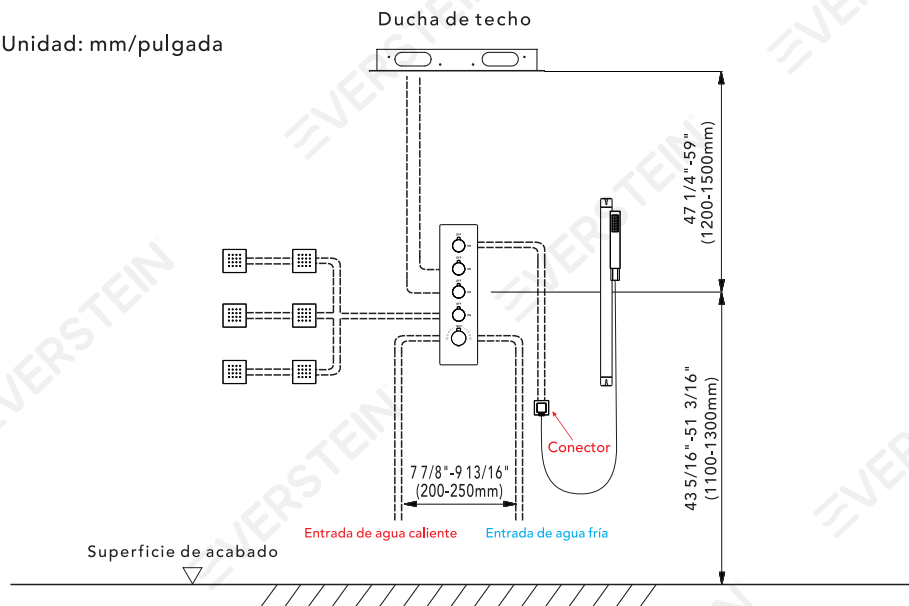

◆ La profundidad de instalación del soporte de ducha y del chorro para el cuerpo

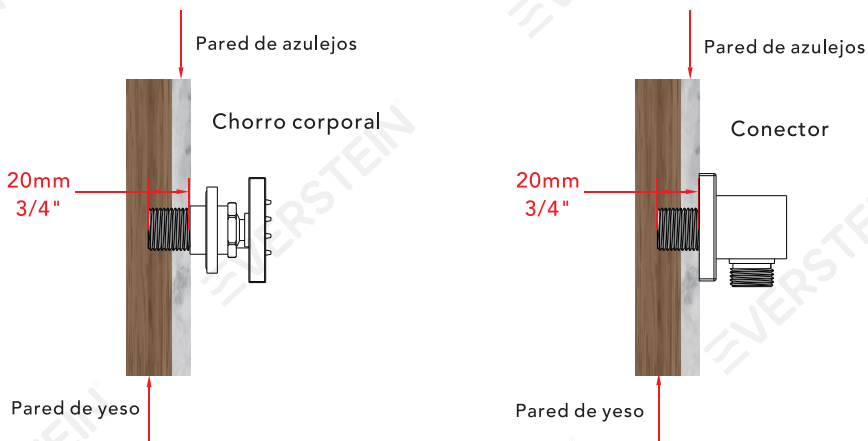

El grosor del azulejo debe calcularse para la instalación. Tamaño del conector de rosca macho: EE.UU.: 1/2"-14NPT, Canadá: 1/2"-14NPT, Europa: G1/2".

◆ Profundidad de Instalación del Cuerpo Principal

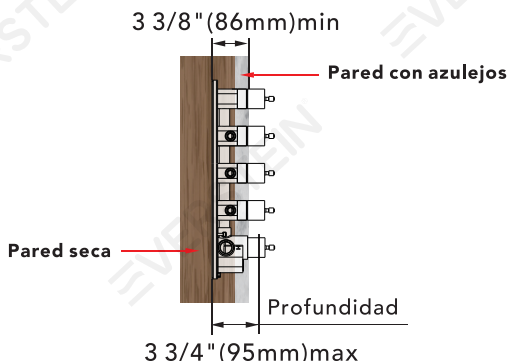
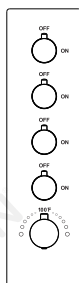

- Aviso: 1. La profundidad de instalación del cuerpo principal no debe ser inferior a 3 3/8" (86 mm) y no más de 3 3/4" (95mm), incluyendo el grosor del azulejo. De lo contrario, la placa de cubierta no podrá ser instalada.
2. El tamaño de apertura del azulejo cerámico debe ser menor que el tamaño de la placa de cubierta.

◆ Instrucciones de Tubería Antes de Colocar Azulejos

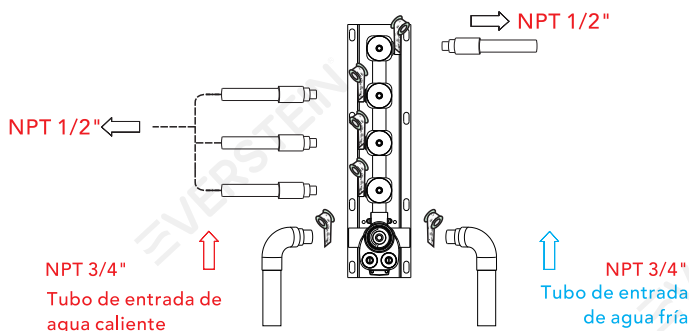

1. Como se muestra en la figura, las tuberías de entrada y salida están pre-enterradas. Por favor, preste atención a la dirección correcta al instalar el cuerpo principal pre-enterrado.
2. Antes de colocar los azulejos, abra el agua para probar si las tuberías de entrada izquierda y derecha están conectadas herméticamente sin fugas. Luego, ajuste el interruptor de flujo a la posición "on" para comprobar si hay fugas en las tuberías de salida mezcladas.

◆ Instalación de la Válvula del Cuerpo Principal

Paso 1

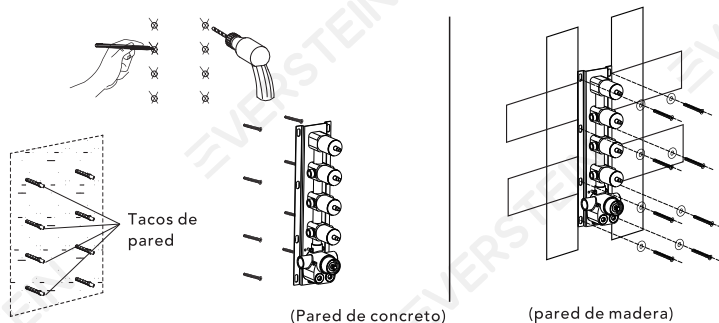

1. Marque según el tamaño de la válvula del cuerpo principal y luego perforo para colocar los anclajes en la pared (pared de concreto).
2. Fije directamente el cuerpo principal a la madera con tornillos (pared de madera).
3. Al instalar el cuerpo principal, por favor marque el lado UP hacia arriba y no lo instale al revés.

▲ Tenga en cuenta que el nivel debe estar paralelo a la pared; de lo contrario, la placa de cubierta no podrá ser instalada.

Paso 2

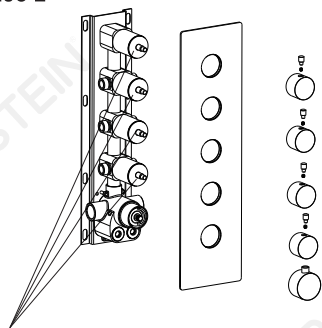

Précautions pour l'installation du volant

- ※ 1. La línea no puede estar mal colocada; debe mantenerse alineada. De lo contrario, la temperatura del agua de 100°F o 38°C no será correcta.



- ※ 2. Por favor, asegúrese de que el anillo localizador de plástico (A) y el pasador localizador del volante (B) se mantengan en la misma línea con 100°F o 38°C. De lo contrario, la temperatura del agua será incorrecta.

No quite el anillo de desgaste blanco; de lo contrario, el volante se dañará

Control del flujo de agua: girar en sentido horario para disminuir y detener, girar en sentido antihorario para aumentar al máximo.

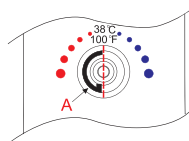

1. Por favor, instale la placa de cubierta, los desviadores de agua y las varillas desviadoras de agua paso a paso.
2. Instale la manija con el tornillo y la tapa de la manija.

◆ Instalación de la varilla de elevación

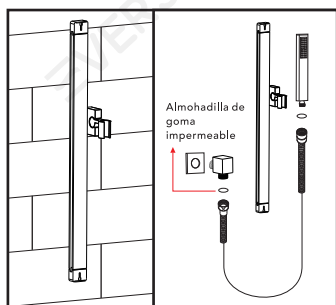
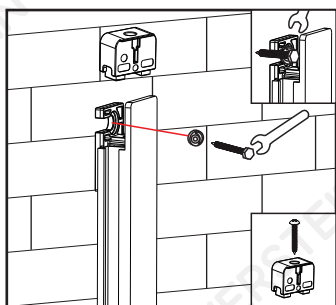
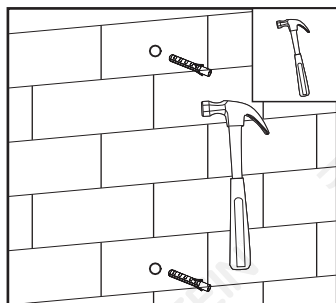
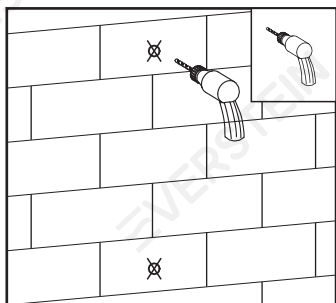
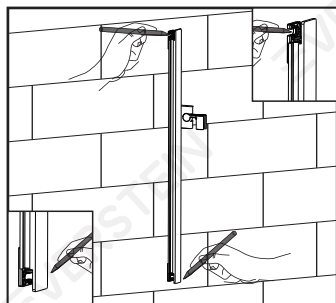
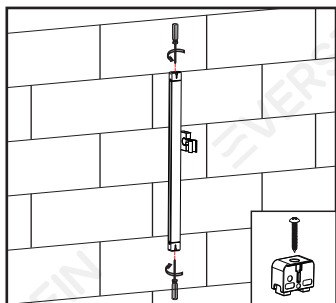

1. Primero, retire los tornillos superiores e inferiores de la barra deslizante.
2. Use un bolígrafo para marcar el tamaño del orificio de giro.
3. Martille las partículas de goma con un martillo.
4. Use una llave para girar los tornillos y luego use un destornillador para instalar el producto.
5. Una vez terminado, la instalación está completa.

◆ Instalación de chorros corporales

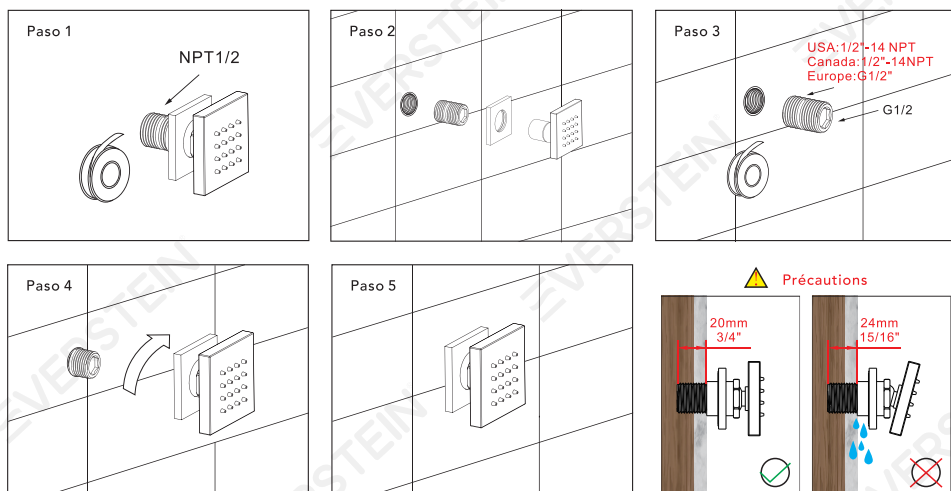

Paso 3: Envuelva con cinta de teflón la tubería roscada de NPT1/2 y atorníllela en la pared.

Paso 4: Atornille el chorro corporal de masaje en la pared.

Paso 5: La instalación está completa.

◆ Schéma de plomberie du pommeau de douche

①

USA: 1/2"-14NPT
Canada: 1/2NPT
Europe: G1/2"

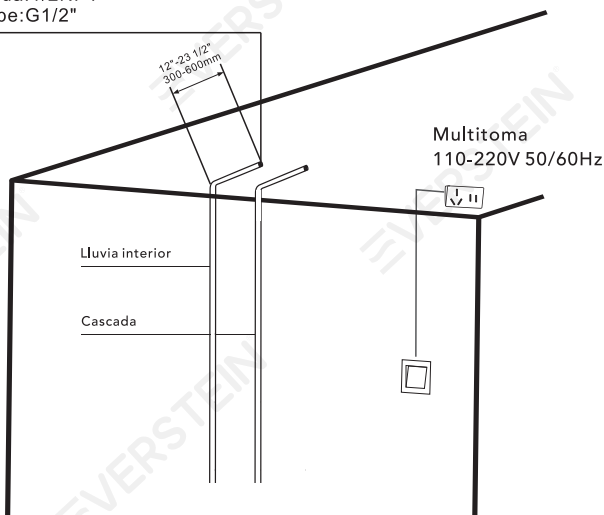

Instale el interruptor de encendido en la posición adecuada, despliegue la tubería de agua y conéctela al cuerpo principal.

◆ Trous dans le plafond

②

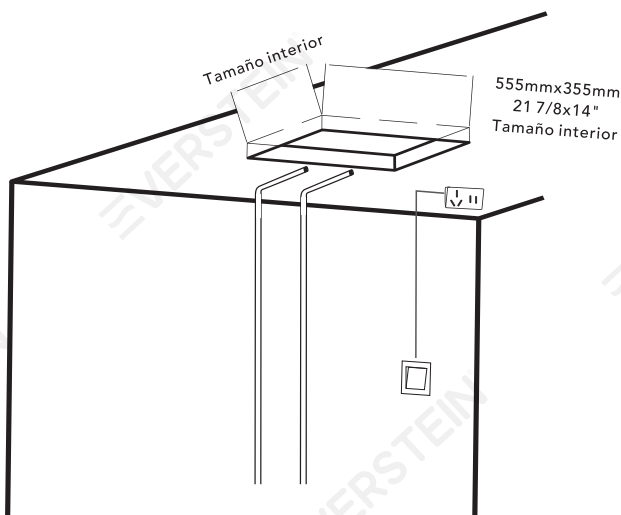

◆ Vista explotada del cabezal de ducha

③

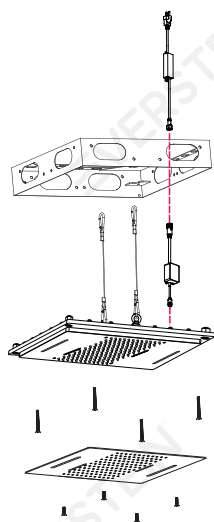

Fuente de alimentación impermeable

Marco de fijación de acero inoxidable

Conexión WiFi

Cuerpo de la cabeza de ducha

Panel decorativo para ducha

Según la marca (Quitar/Instalar) en la parte superior del panel del cabezal de ducha, desatornille el panel decorativo de la ducha, el cuerpo del cabezal de ducha y el marco de fijación, respectivamente.

◆ Instalación del marco de fijación

④

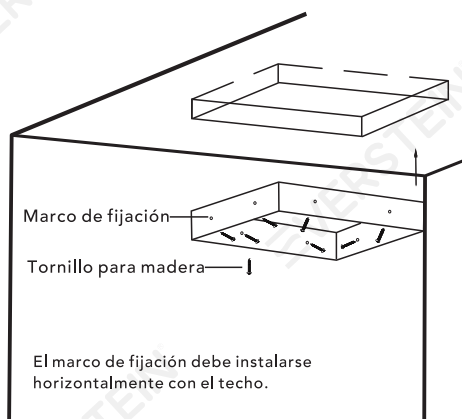

Fije el marco de fijación al marco de madera con tornillos.

◆ Distribución de la energía

⑤

Multitoma
110-220V50/60HZ

Entrada del transformador: 100~277V
50/60Hz Salida: 2.5A

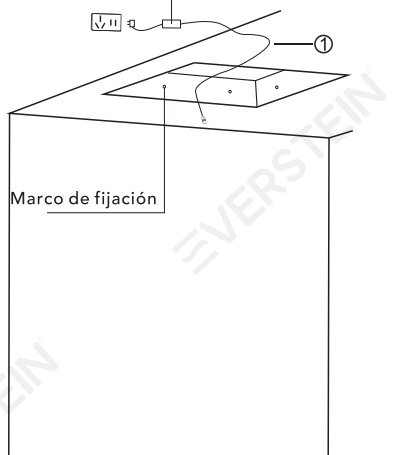

◆ Conexión LED (Línea única)

⑥

Multitoma
110-220V50/60Hz

Entrada del transformador: 100-277V
50/60Hz Salida: 2.5A

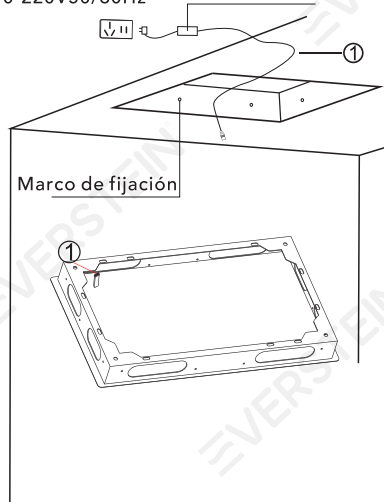

① Para fijar el controlador WiFi, envuélvalo con cinta adhesiva para evitar que se caiga.

② Para conectar la fuente de alimentación y el WiFi

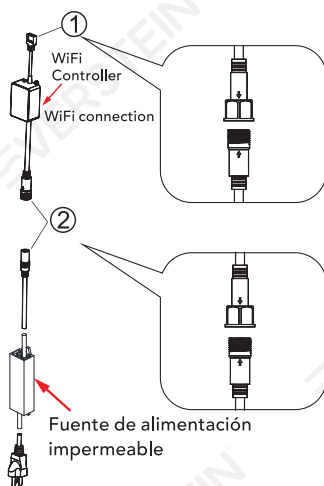

◆ Instalación del cuerpo del cabezal de ducha

⑦

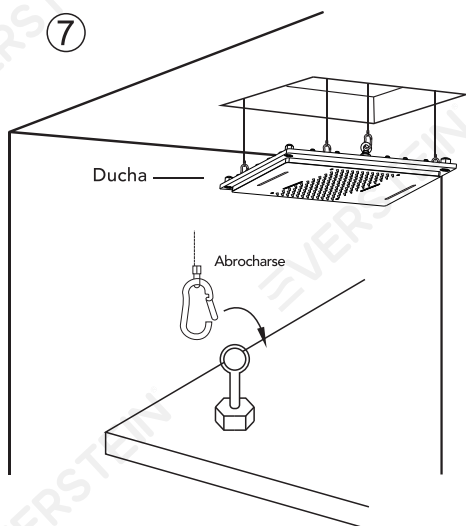

◆ Distribución para la tubería de agua

⑧

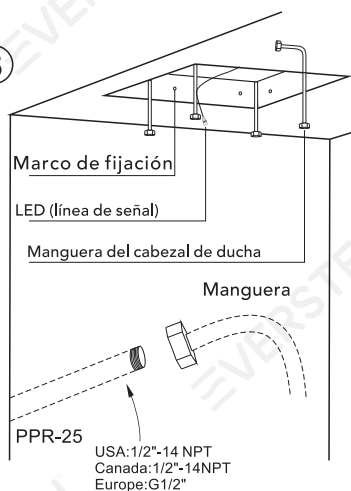

Conecte un extremo de la tubería corrugada a la tubería de agua PPR empotrada y el otro extremo a la tubería de entrada de agua en la parte posterior del cabezal de ducha.

◆ Conexión de la tubería de entrada de agua

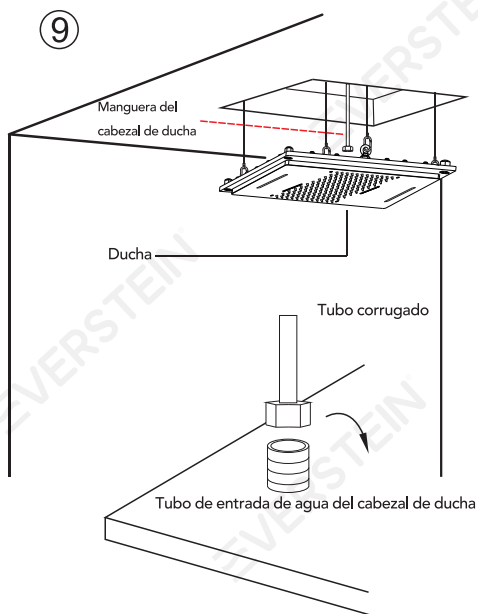

◆ Prueba de agua

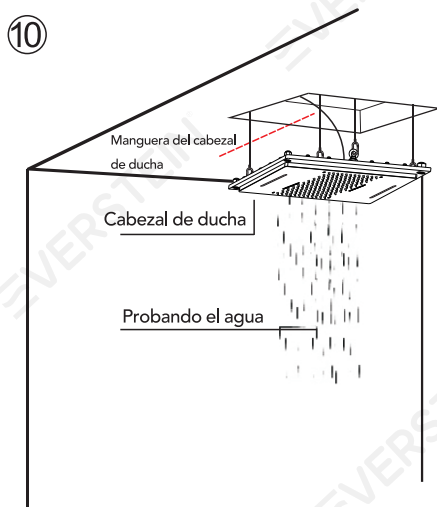

◆ Instalación del cabezal de ducha

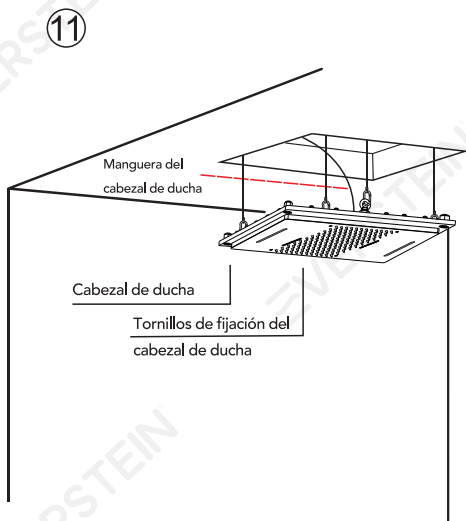

◆ Instalación del panel decorativo de la ducha

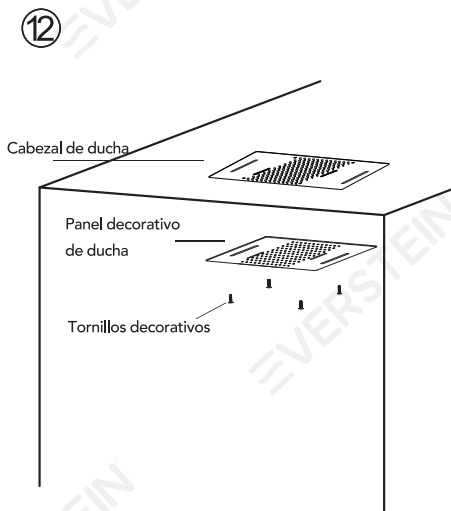

◆ Instrucción remota de LED Touch

El remoto táctil tiene 9 teclas táctiles, cada una de las cuales funciona de la siguiente manera:

Se ilustran las conexiones del controlador:

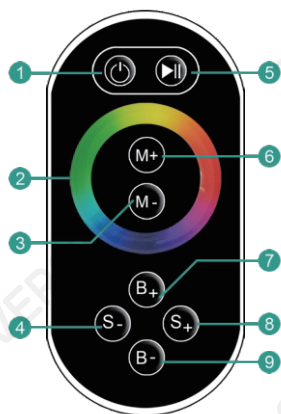

- ① Encender / apagar
- ⑤ Cambio de modo
- ② Anillo táctil de color
- ③/⑥ Ajuste de la temperatura del color
- ④/⑧ Ajuste de velocidad dinámica
- ⑦/⑨ Ajuste de brillo dinámico

Mode:

NO	FUNCIÓN	Remoto
1	Rojo estático	El brillo es ajustable. La velocidad no es ajustable.
2	Verde estático	
3	Azul estático	
4	R G B Jumping	
5	Verde azul estático	
6	Amarillo estático	
7	Blanco estático	
8	Morado estático	El brillo es ajustable La velocidad es ajustable
9	R G B Gradual	
10	7 colores saltando	
11	7-Colors Gradual	

2. Gestión de la fuente de alimentación:

El control remoto ingresará al modo de espera (estado intocable) si se presiona durante más de 20 segundos. Si esto ocurre, por favor, agite ligeramente una vez y el control remoto volverá al estado de trabajo normal (estado táctil).

3. Instrucción de luz del indicador:

3.1. Cuando la luz indicadora PWR es brillante, el control remoto está inactivo o envía una señal; Cuando la luz PWR es APAGADO, entrará en modo de espera.

3.2. Cuando RF es brillante, significa que el control remoto está enviando señal; OFF significa que no hay señal de envío de señal.

Observaciones:

1. Este producto debe ser comisionado e instalado por personal calificado.
2. Este producto no puede ser impermeable; Necesita ser protegido del sol y la lluvia. Si se instala Al aire libre, use una caja impermeable.
3. Las condiciones de disipación de calor bueno extenderán la vida útil del controlador LED. Instale el producto en un entorno bien ventilado
4. Por favor, no instale ni use dichos productos en Lightning, Thunder, Fuerte Magnetic o Alto Aplicaciones de voltaje.
5. Por favor, verifique si el voltaje de salida de la fuente de alimentación LED utilizada cumple con el producto
Requisitos de rango de voltaje.
6. El diámetro del cable utilizado debe ser suficiente para soportar la luminaria LED conectada, y asegúrese de que el cableado esté seguro para evitar el sobrecalentamiento del cable o la desencadenante de contacto deficiente un accidente.
7. Antes de la depuración de poder, asegúrese de que todo el cableado sea correcto para evitar daños al luminaria debido a errores de cableado.